

# HAGS®

## Omega Ext Module

MASW73180

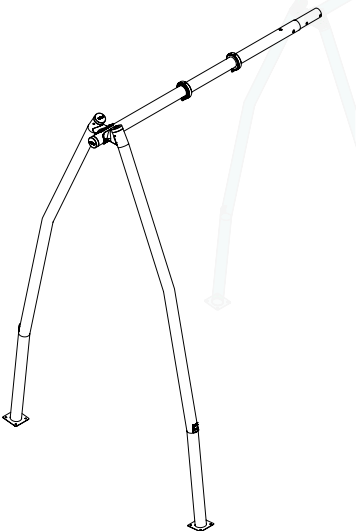

SW73180

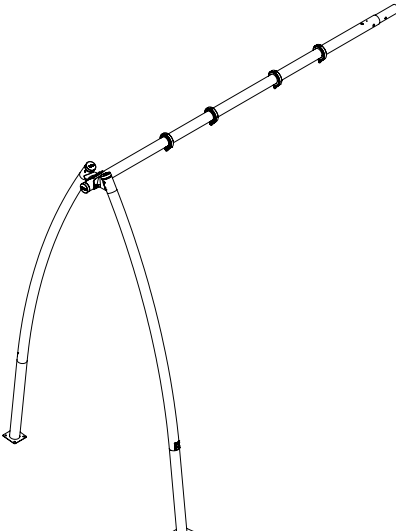

SW73172

### CC/BM

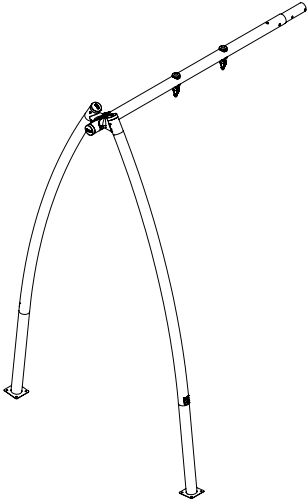
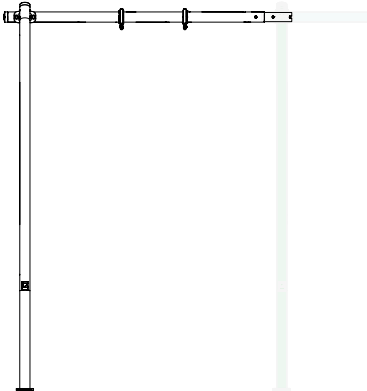

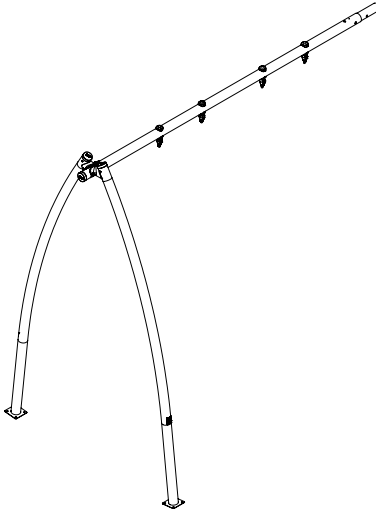

SW51391

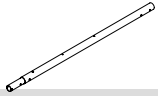

SW51096

1	SW72817		1x	Ø 88.9 x 3808mm	33.35kg
2	SW51075		2x	Ø88.9 x 3351mm	16.94kg
3	8042812		2x	ISO7042-M16-8	0.043kg
4	SW31244		2x	Ø90 x 143 mm	0.2kg
5	8027762		4x	M6x25-8.8-(ISO7380)	0.006kg
6	8057703		2x	ISO4014-M16x120-8.8	0.2280kg
7	8058078		2x	ISO7092-17x28x2.5	0.008kg
8	SW72826		1x	Ø88.9 X 2472mm	21.42kg

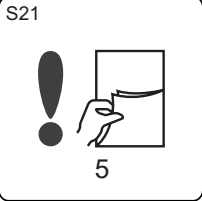
9	SW51025		1x	Ø 88.9 x 3808	24.007kg
10	SW51024		1x	Ø 88.9 x 3351	18.56kg
11	SW31278		2/4x	60 X 60 X 220mm	1.41kg
<b>SW51096 &amp; SW51391</b>					

S20



1 x 2,0

S17



S18





S19



S12



kg  
86/74

S25	
S2 (50mm)	≥C20-25
	7 x 24
	101

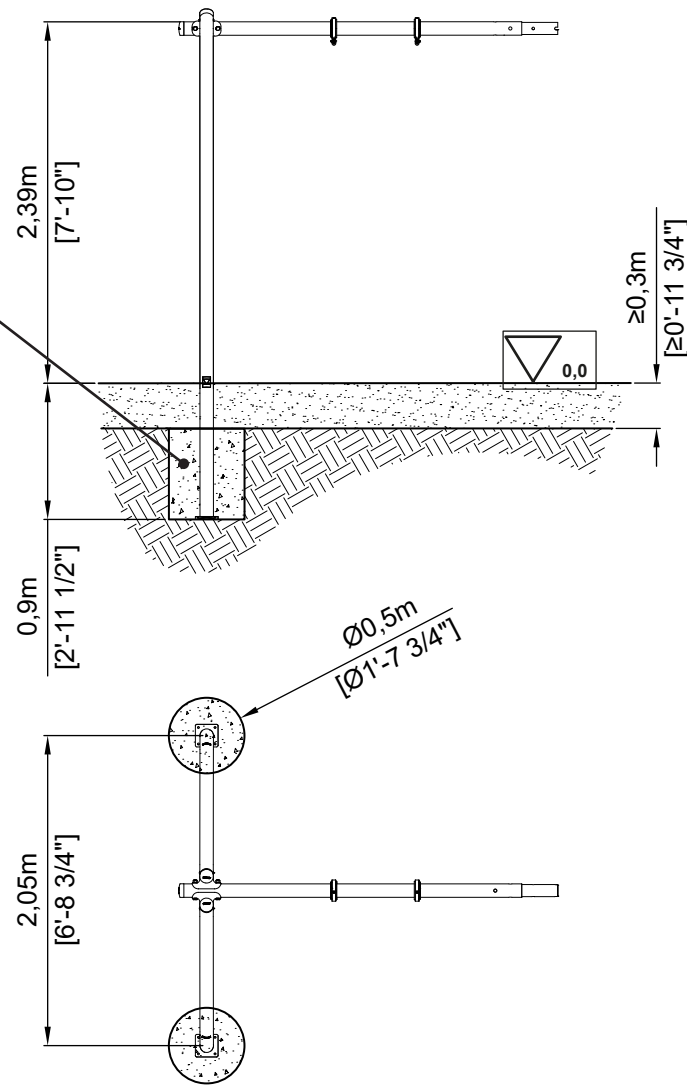

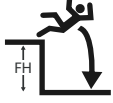
S39	
≥EN1176	
≥ASTM F1487	
≥CPSC	
≥CSA Z614	

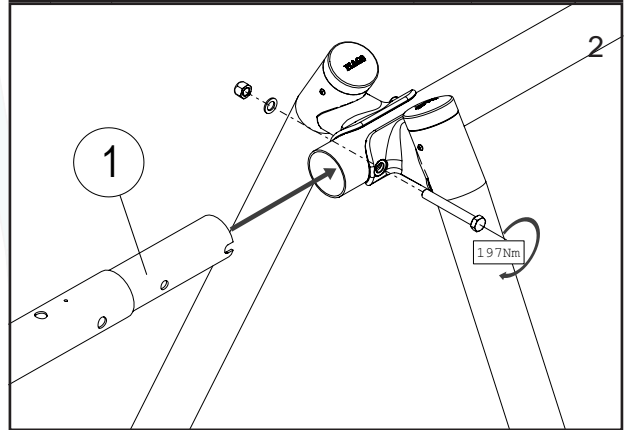
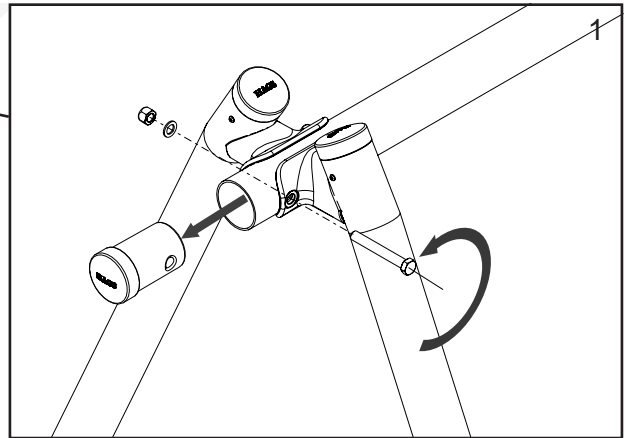
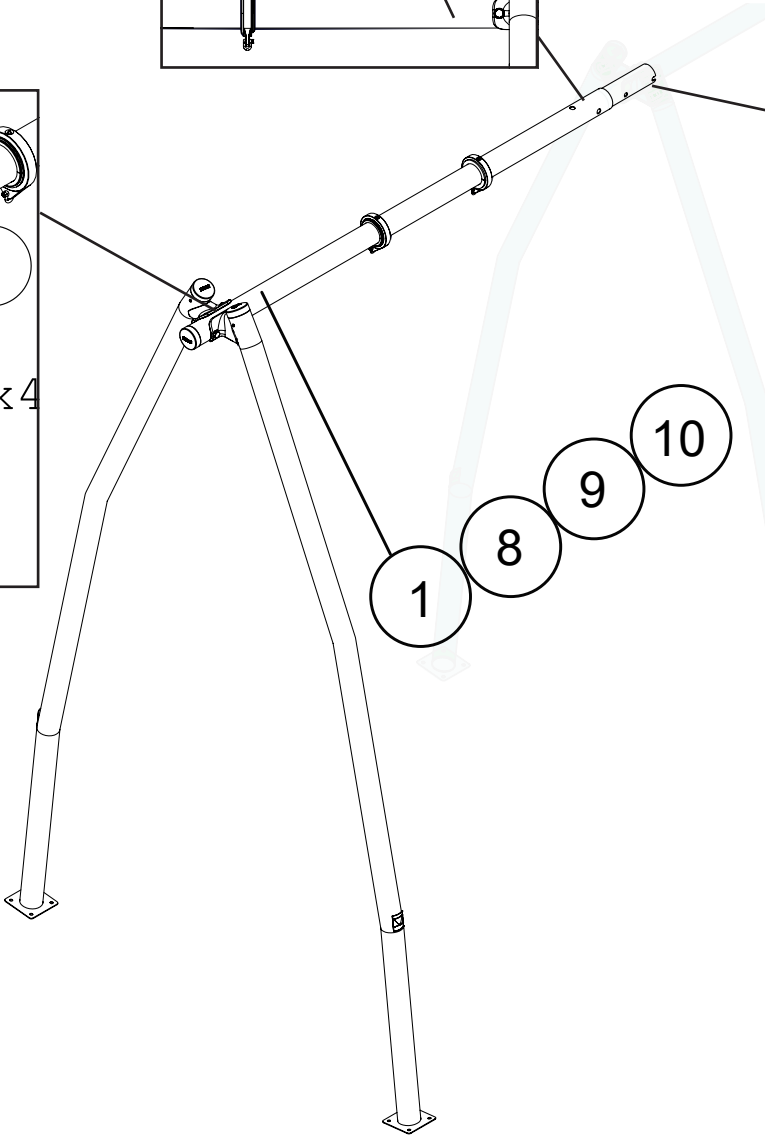
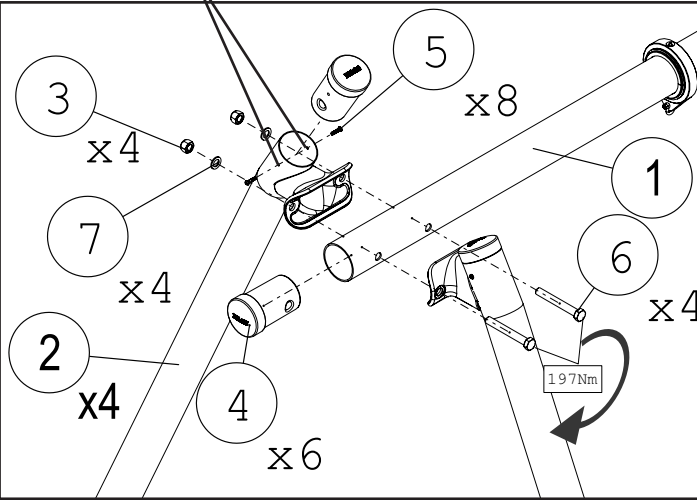
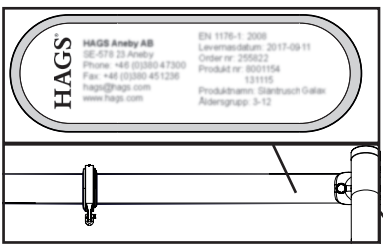
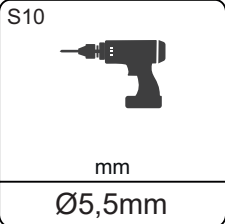

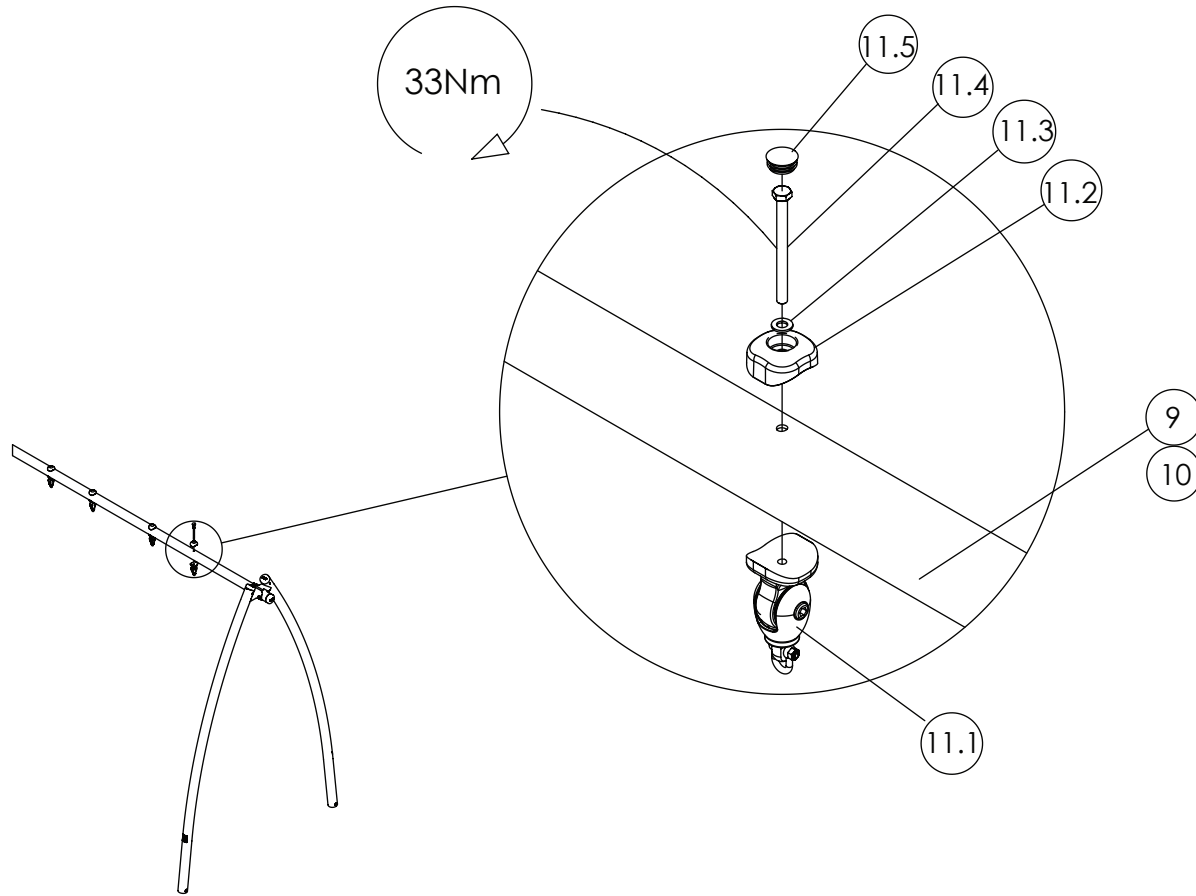

NR.	Description MA	Item Number	Qty
11.1	Swing joint	8050617	2/4
11.2	Cover		
11.3	Ø11x24x2		
11.4	M6S M10x120 mm		
11.5	Top cover		

SW73172 & SW51096

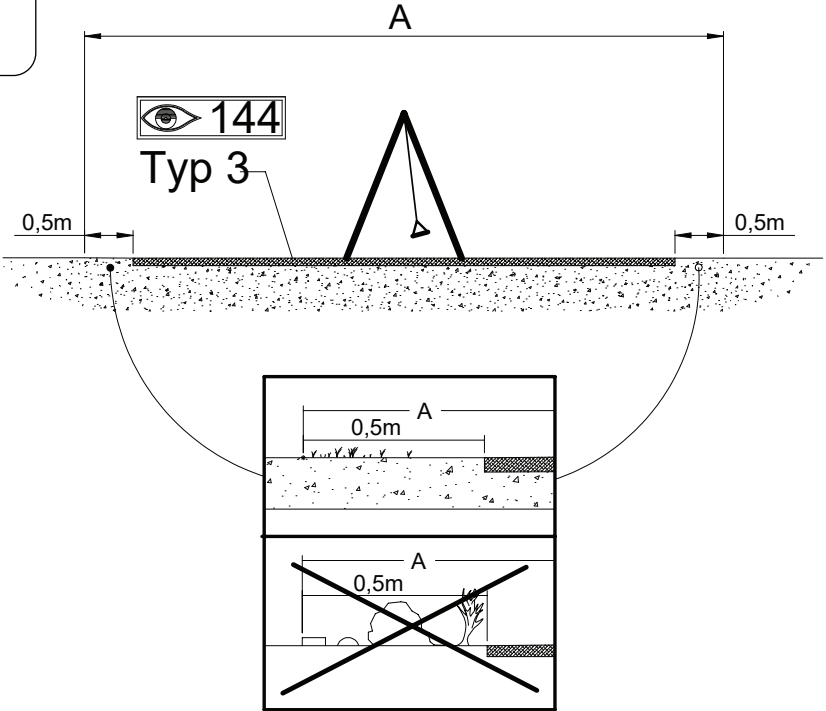
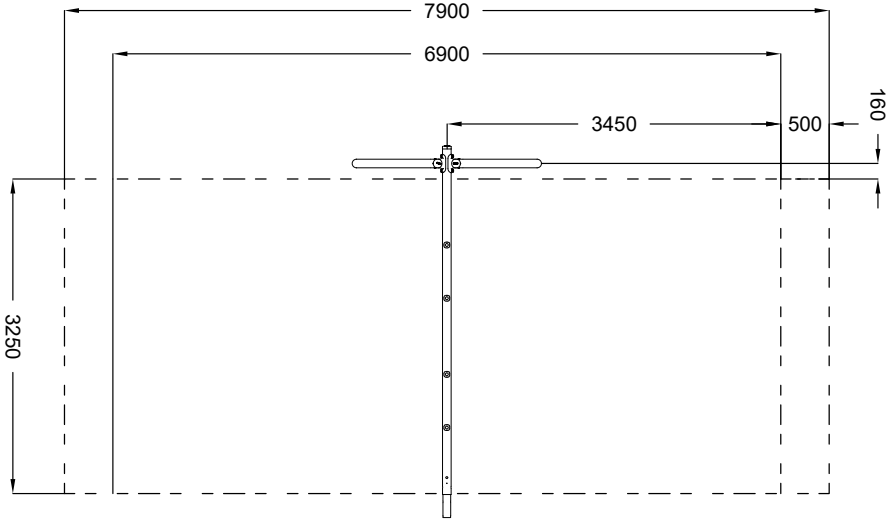
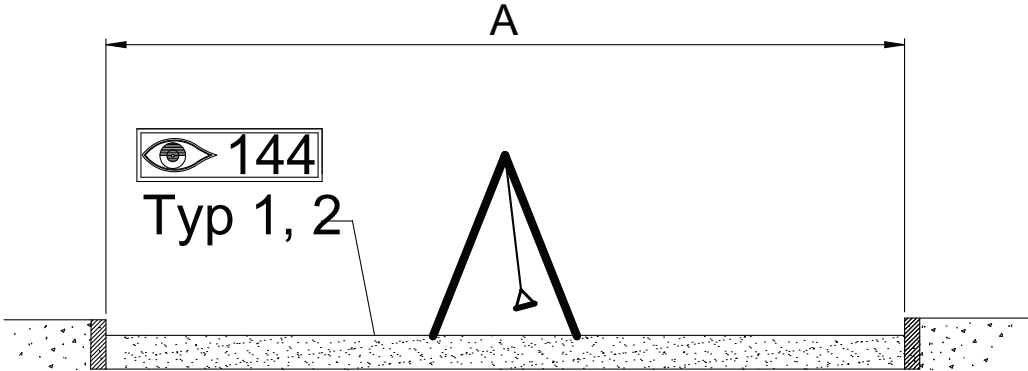
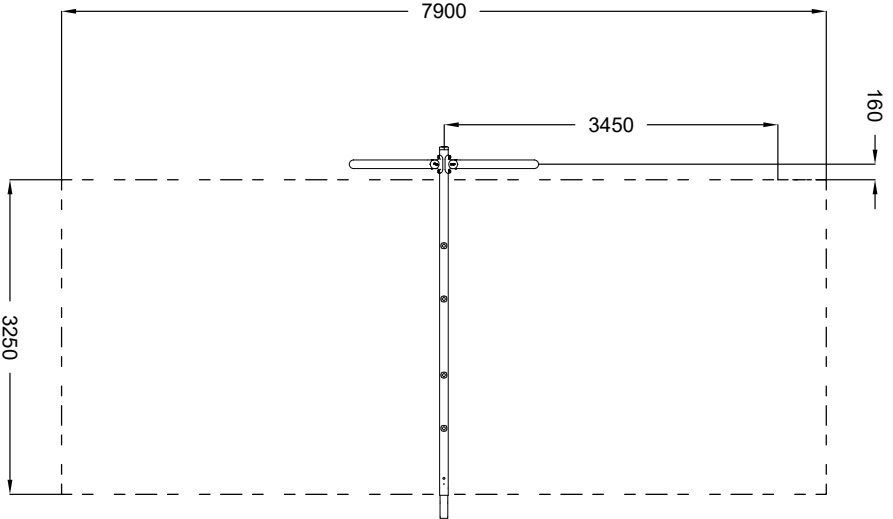
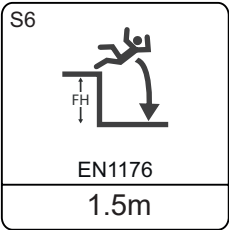

# SW73180 & SW51391

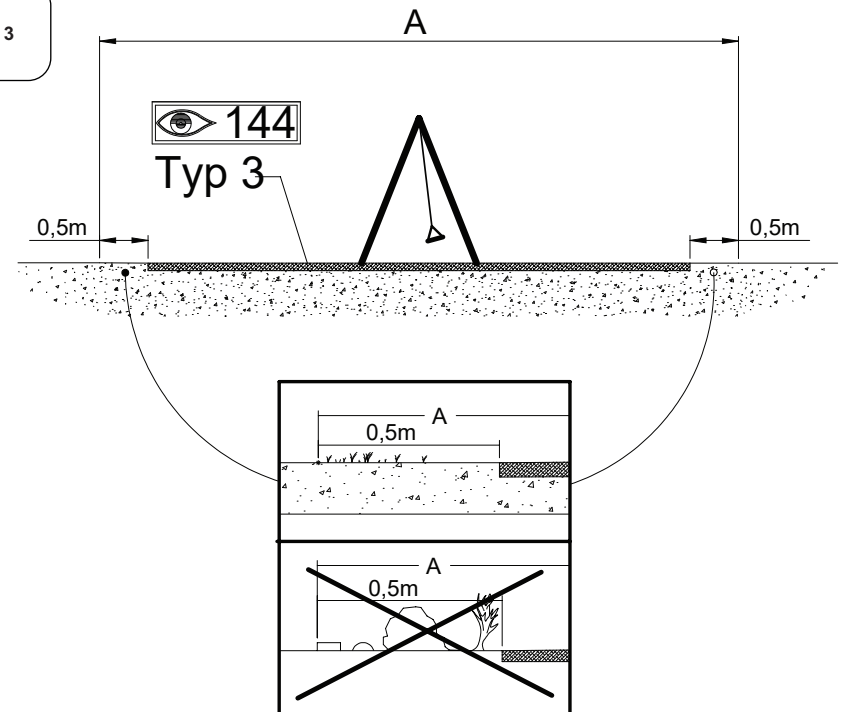
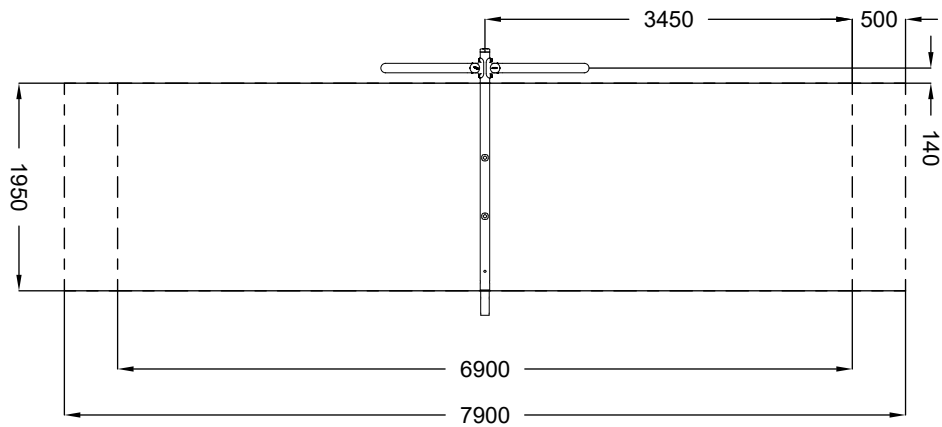
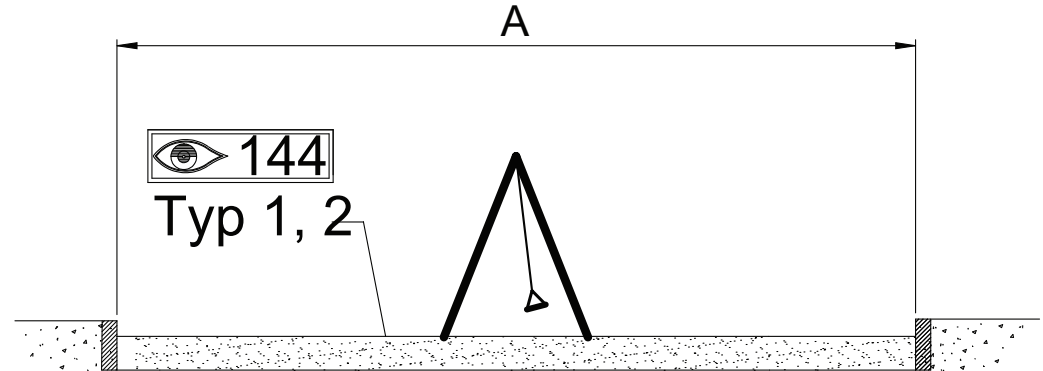
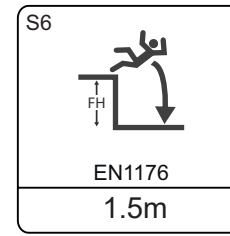
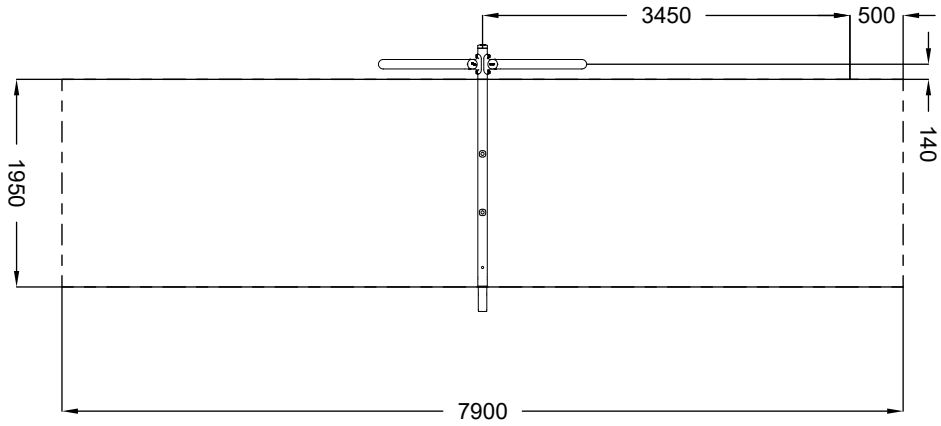

# SW73172 & SW51096

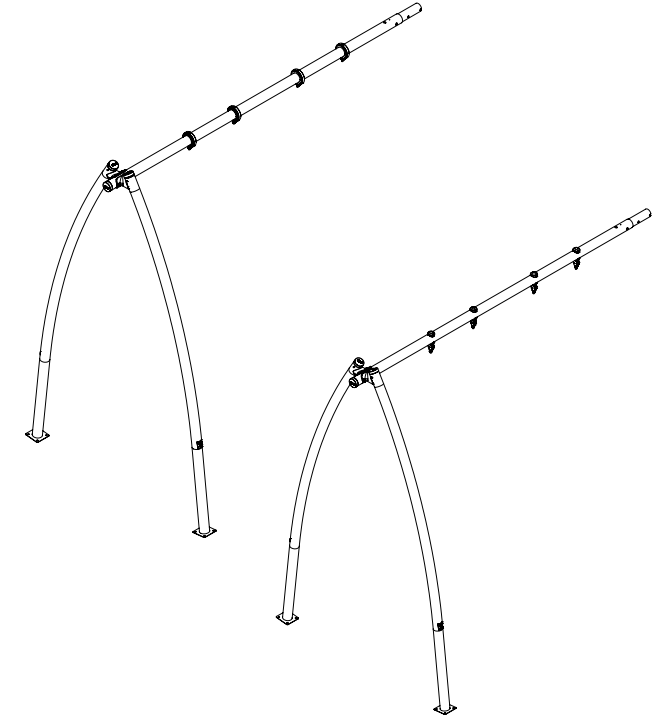
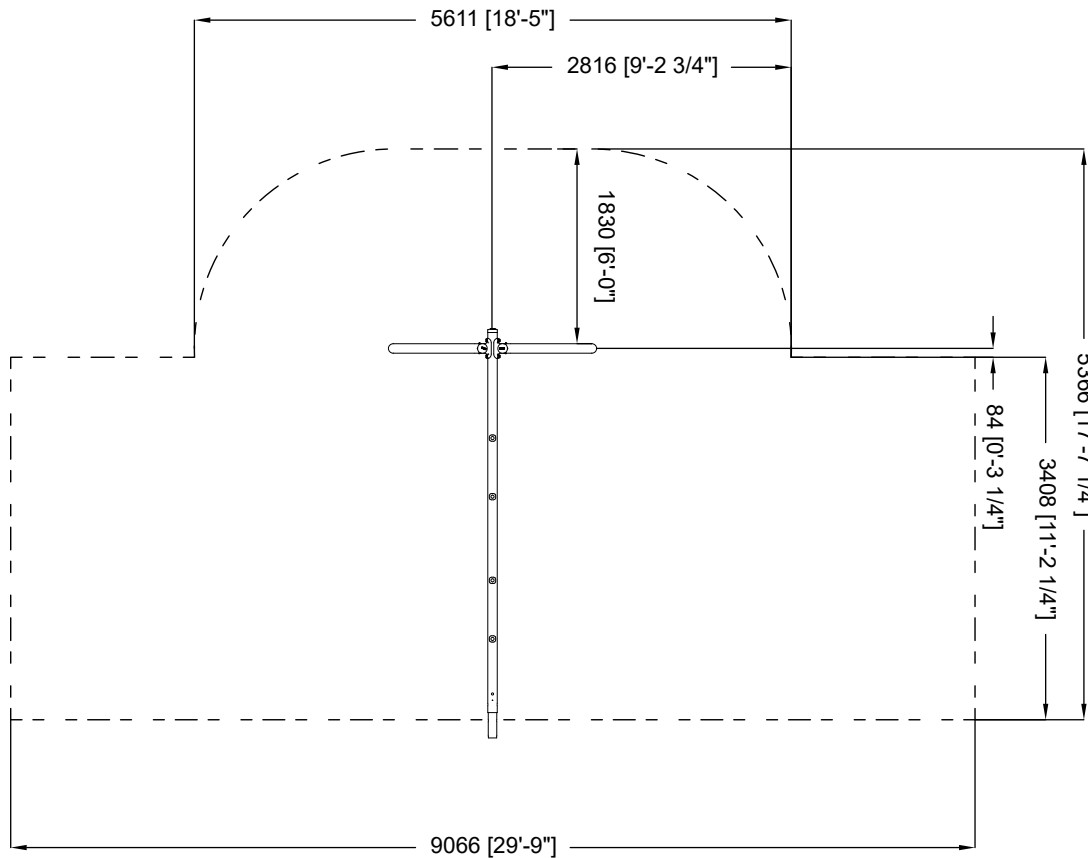
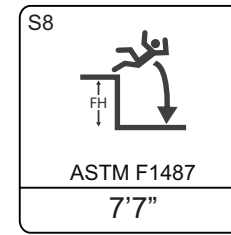

**WARNING**  
Playground equipment installed over hard surfaces such as concrete, asphalt or packed earth may result in serious injury or death from falls. Make sure that appropriate safety surfacing is present, before allowing children to play.

**WARNING**  
Children have strangled and died while their clothes caught on slides and other playground equipment. Before allowing children to play, remove helmets, scarves, necklaces, hood cords, neck drawstrings, and mittens connected through the sleeves. Also, remove any foreign ropes, strings, or shoe laces that may be tied to equipment.

**WARNING**  
All playground equipment and rubber surfacing may become hot enough to cause burns. Check for hot surfaces before allowing children to play. Children should wear appropriate shoes at all times.

**WARNING**  
Playing tag or running on or under playground equipment can lead to serious injuries from falls, collisions, and head strikes. Do not run on or under playground equipment. Pay attention while playing and be careful.

**"play smart" rules**

- ✓ Do not play on broken or damaged equipment. Report it.
- ✓ Do not play without adequate safety surfacing below and around equipment.
- ✓ No helmets, necklaces or drawstrings should be worn while on equipment.
- ✓ Be careful of hot paly surfaces and always wear shoes while playing.
- ✓ Do not play tag or run on playground equipment and do not jump off of equipment.
- ✓ Watch your head! Do not run under bridges, decks, stairs, or other equipment.
- ✓ Be careful when equipment is wet. Do not play on snowy or icy equipment.
- ✓ Do not climb on roofs, railings, or posts, or on top of crawl through tube slides.
- ✓ Slide sitting down, feet first, and one at a time. Do not slide up chutes or tubes.
- ✓ Adults - do not slide with a child on your lap. It can injure your child's legs.
- ✓ Before letting go of overhead bars, hang down still, bend your knees a little and drop straight down with both feet.
- ✓ Swing sitting down and do not jump out while swinging. Do not twist chains.



# SW73180 & SW51391

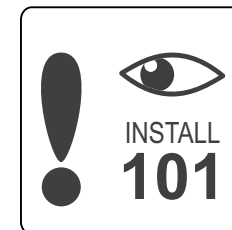
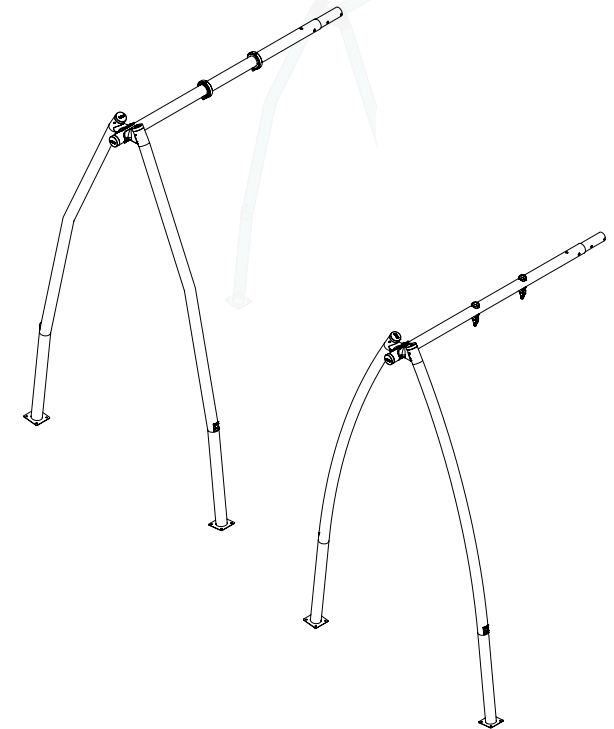
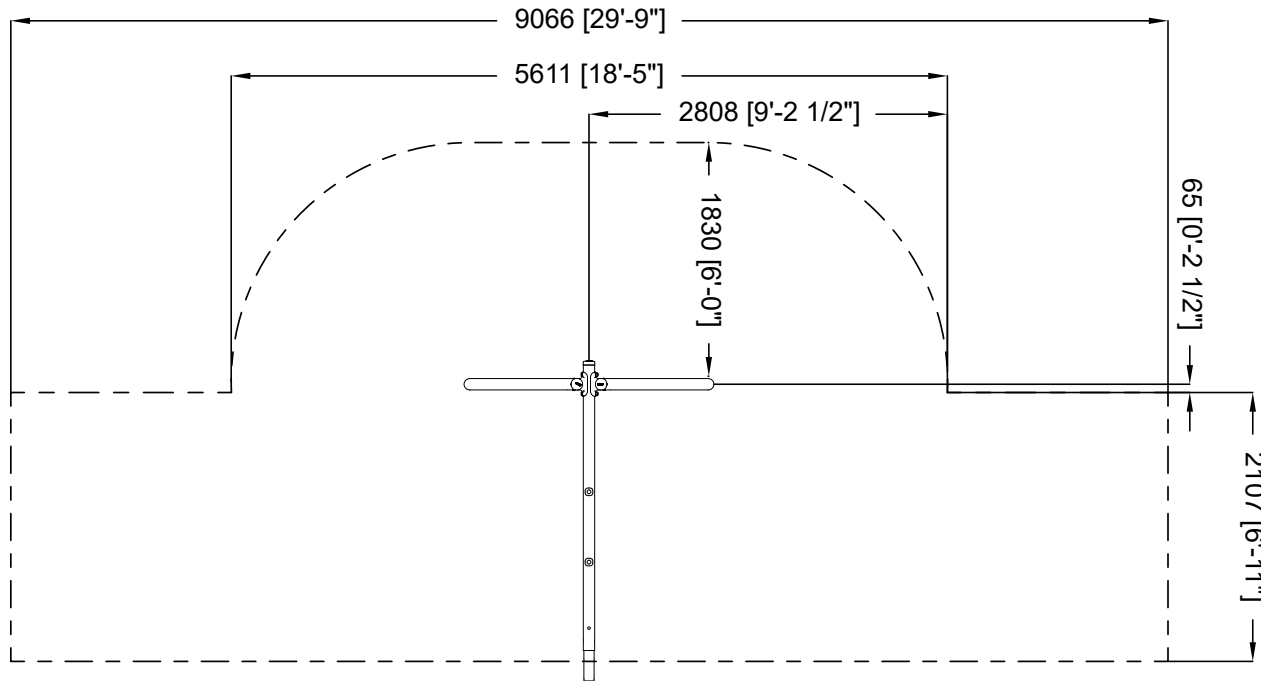
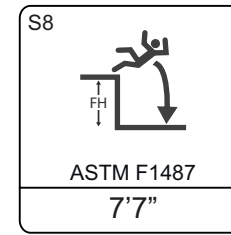

**WARNING**  
Playground equipment installed over hard surfaces such as concrete, asphalt or packed earth may result in serious injury or death from falls. Make sure that appropriate safety surfacing is present, before allowing children to play.

**WARNING**  
Children have strangled and died while their clothes caught on slides and other playground equipment. Before allowing children to play, remove helmets, scarves, necklaces, hood cords, neck drawstrings, and mittens connected through the sleeves. Also, remove any foreign ropes, strings, or shoe laces that may be tied to equipment.

**WARNING**  
All playground equipment and rubber surfacing may become hot enough to cause burns. Check for hot surfaces before allowing children to play. Children should wear appropriate shoes at all times.

**WARNING**  
Playing tag or running on or under playground equipment can lead to serious injuries from falls, collisions, and head strikes. Do not run on or under playground equipment. Pay attention while playing and be careful.

**"play smart" rules**

- ✓ Do not play on broken or damaged equipment. Report it.
- ✓ Do not play without adequate safety surfacing below and around equipment.
- ✓ No helmets, necklaces or drawstrings should be worn while on equipment.
- ✓ Be careful of hot paly surfaces and always wear shoes while playing.
- ✓ Do not play tag or run on playground equipment and do not jump off of equipment.
- ✓ Watch your head! Do not run under bridges, decks, stairs, or other equipment.
- ✓ Be careful when equipment is wet. Do not play on snowy or icy equipment.
- ✓ Do not climb on roofs, railings, or posts, or on top of crawl through tube slides.
- ✓ Slide sitting down, feet first, and one at a time. Do not slide up chutes or tubes.
- ✓ Adults - do not slide with a child on your lap. It can injure your child's legs.
- ✓ Before letting go of overhead bars, hang down still, bend your knees a little and drop straight down with both feet.
- ✓ Swing sitting down and do not jump out while swinging. Do not twist chains.

# SW73172 & SW51096

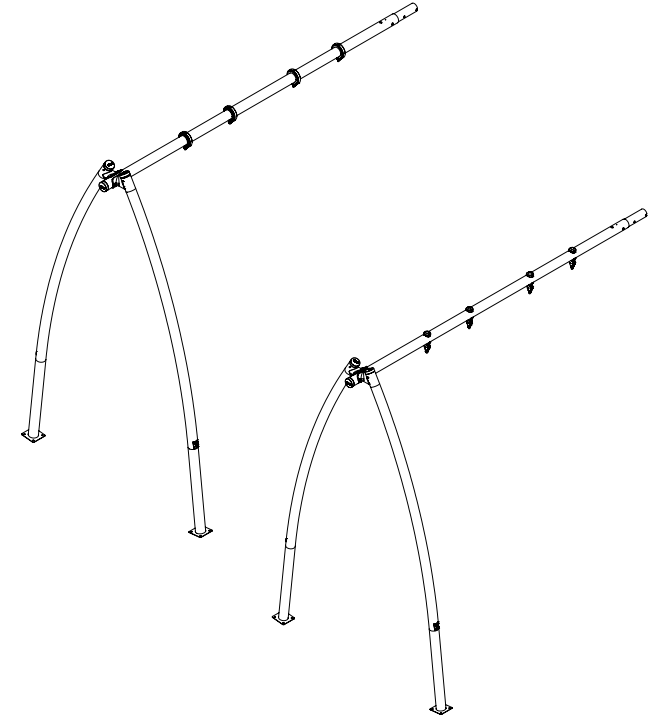
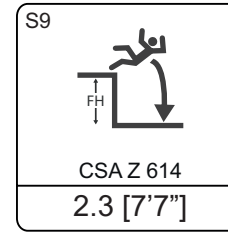
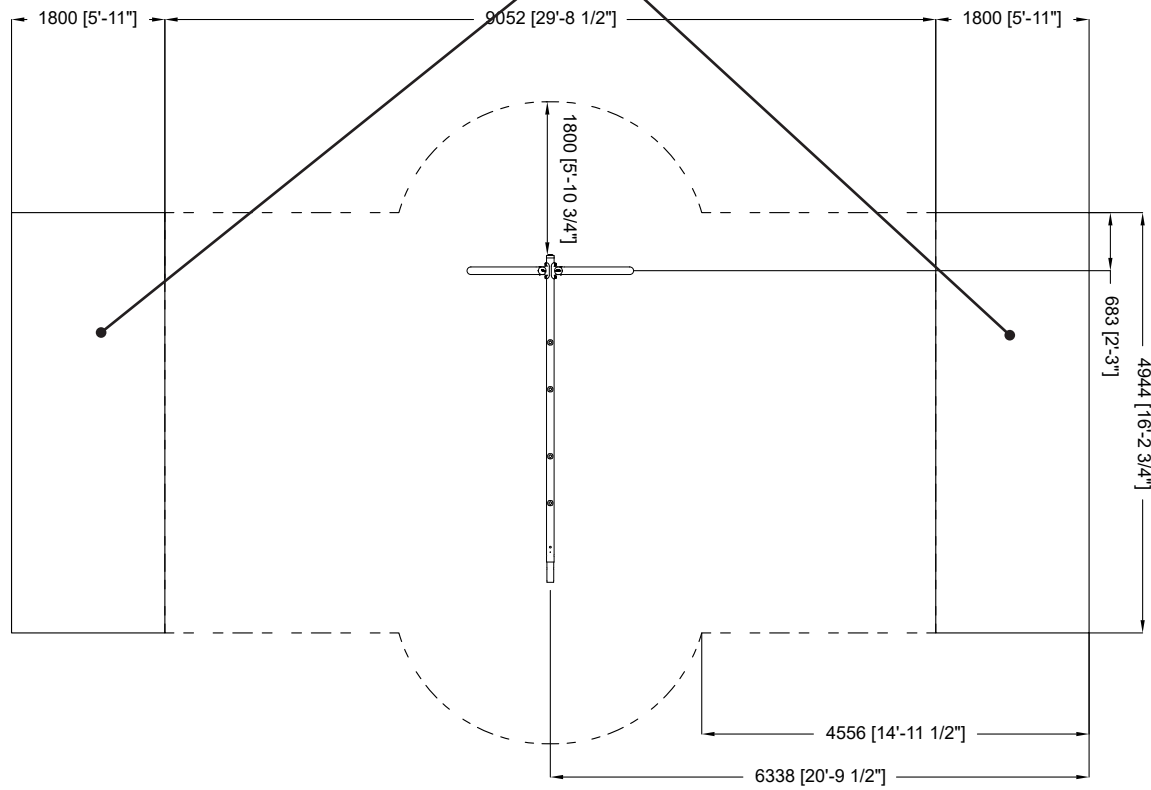
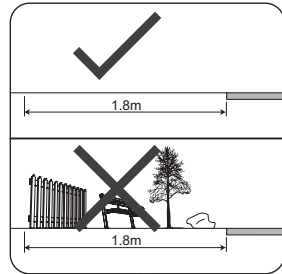

**WARNING**  
Playground equipment installed over hard surfaces such as concrete, asphalt or packed earth may result in serious injury or death from falls. Make sure that appropriate safety surfacing is present, before allowing children to play.

**WARNING**  
Children have strangled and died while their clothes caught on slides and other playground equipment. Before allowing children to play, remove helmets, scarves, necklaces, hood cords, neck drawstrings, and mittens connected through the sleeves. Also, remove any foreign ropes, strings, or shoe laces that may be tied to equipment.

**WARNING**  
All playground equipment and rubber surfacing may become hot enough to cause burns. Check for hot surfaces before allowing children to play. Children should wear appropriate shoes at all times.

**WARNING**  
Playing tag or running on or under playground equipment can lead to serious injuries from falls, collisions, and head strikes. Do not run on or under playground equipment. Pay attention while playing and be careful.

**"play smart" rules**

- ✓ Do not play on broken or damaged equipment. Report it.
- ✓ Do not play without adequate safety surfacing below and around equipment.
- ✓ No helmets, necklaces or drawstrings should be worn while on equipment.
- ✓ Be careful of hot paly surfaces and always wear shoes while playing.
- ✓ Do not play tag or run on playground equipment and do not jump off of equipment.
- ✓ Watch your head! Do not run under bridges, decks, stairs, or other equipment.
- ✓ Be careful when equipment is wet. Do not play on snowy or icy equipment.
- ✓ Slide sitting down, feet first, and one at a time. Do not slide up chutes or tubes.
- ✓ Adults - do not slide with a child on your lap. It can injure your child's legs.
- ✓ Before letting go of overhead bars, hang down still, bend your knees a little and drop straight down with both feet.
- ✓ Swing sitting down and do not jump out while swinging. Do not twist chains.

# SW73180 & SW51391

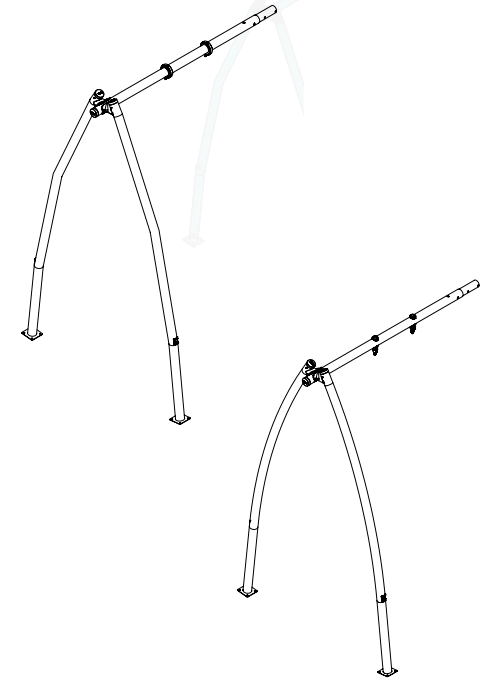
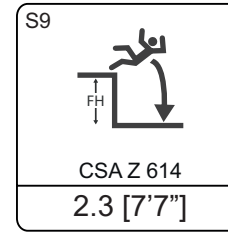
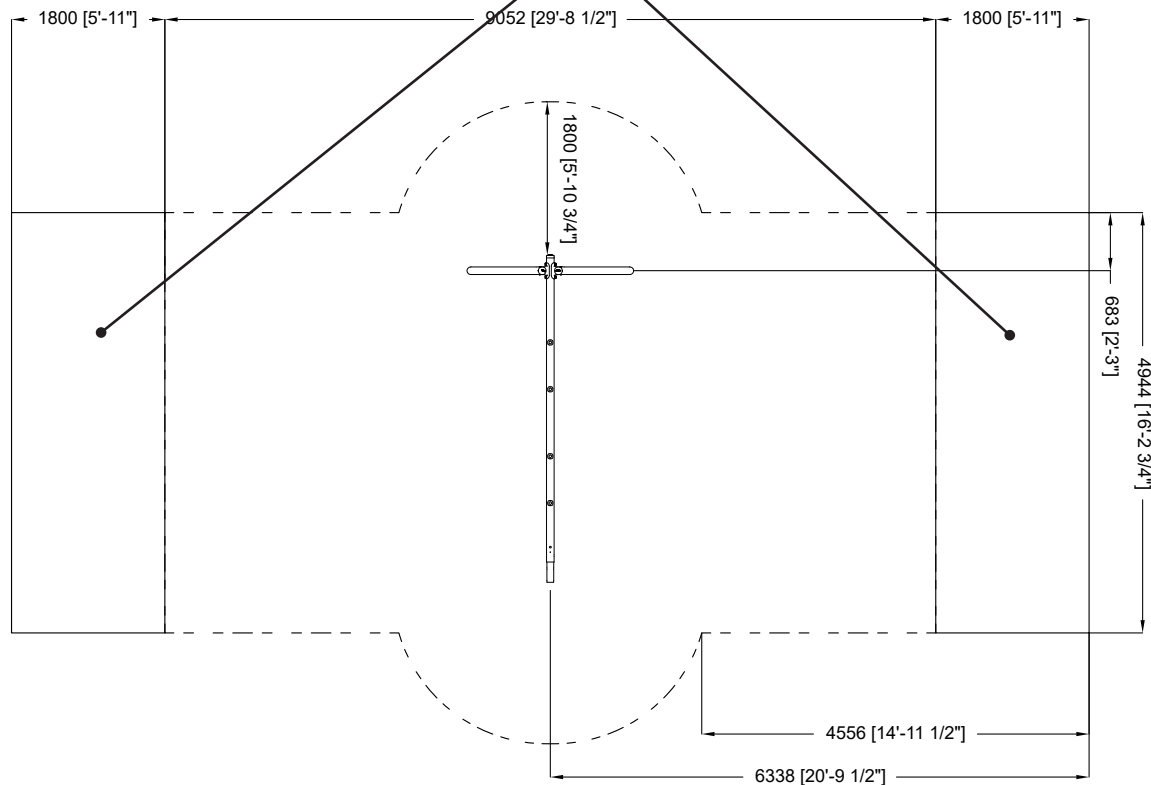
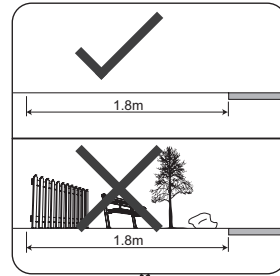

**WARNING**  
Playground equipment installed over hard surfaces such as concrete, asphalt or packed earth may result in serious injury or death from falls. Make sure that appropriate safety surfacing is present, before allowing children to play.

**WARNING**  
Children have strangled and died while their clothes caught on slides and other playground equipment. Before allowing children to play, remove helmets, scarves, necklaces, hood cords, neck drawstrings, and mittens connected through the sleeves. Also, remove any foreign ropes, strings, or shoe laces that may be tied to equipment.

**WARNING**  
All playground equipment and rubber surfacing may become hot enough to cause burns. Check for hot surfaces before allowing children to play. Children should wear appropriate shoes at all times.

**WARNING**  
Playing tag or running on or under playground equipment can lead to serious injuries from falls, collisions, and head strikes. Do not run on or under playground equipment. Pay attention while playing and be careful.

**"play smart" rules**

- ✓ Do not play on broken or damaged equipment. Report it.
- ✓ Do not play without adequate safety surfacing below and around equipment.
- ✓ No helmets, necklaces or drawstrings should be worn while on equipment.
- ✓ Be careful of hot play surfaces and always wear shoes while playing.
- ✓ Do not play tag or run on playground equipment and do not jump off of equipment.
- ✓ Watch your head! Do not run under bridges, decks, stairs, or other equipment.
- ✓ Be careful when equipment is wet. Do not play on snowy or icy equipment.
- ✓ Slide sitting down, feet first, and one at a time. Do not slide up chutes or tubes.
- ✓ Adults - do not slide with a child on your lap. It can injure your child's legs.
- ✓ Before letting go of overhead bars, hang down still, bend your knees a little and drop straight down with both feet.
- ✓ Swing sitting down and do not jump out while swinging. Do not twist chains.