



Assembly View

Installation Instructions

Playworld Systems[®]
Models XX0697, XX0698 and XX0699

PlayForm 7





Daughter Sheet Plastic, Laminated Bamboo
and Polycarbonate Panel

Installation Preparation

Recommended Crew: One (1) adult

Installation Time: 0.25 hour

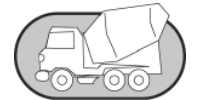
ICON KEY

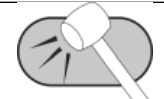
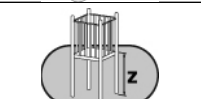
	Fully Tighten Hardware		Add 1 Drop of Thread Locking Adhesive
	Do Not Fully Tighten Hardware		Pour Concrete
	Drill		Dig Footing Holes
	Hammer		Critical Fall Height

Installation Instructions

Follow the details in alphabetical order. For clarification, each detail references the step description. The step descriptions start on page 3.

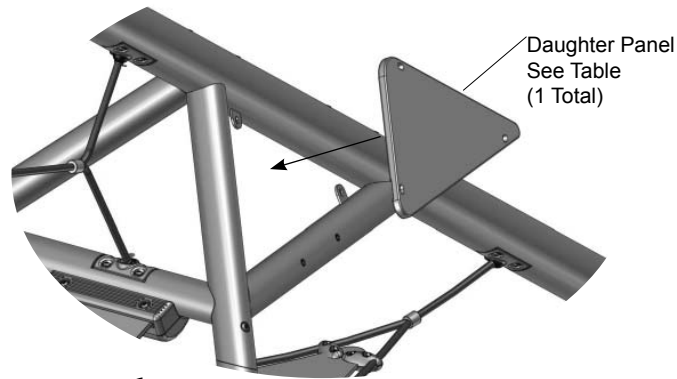

Panel Model	Type	Part Number	Bolt Number	Bolt Description
ZZXX0697	Sheet Plastic	BFC3631	BAE0659	3/8"-16 x .75" Button Head
ZZXX0698	Laminated Bamboo	BFC3621	BAE0659	3/8"-16 x .75" Button Head
ZZXX0699	Polycarbonate	BFC3627	BAE0661	3/8"-16 x .50" Button Head

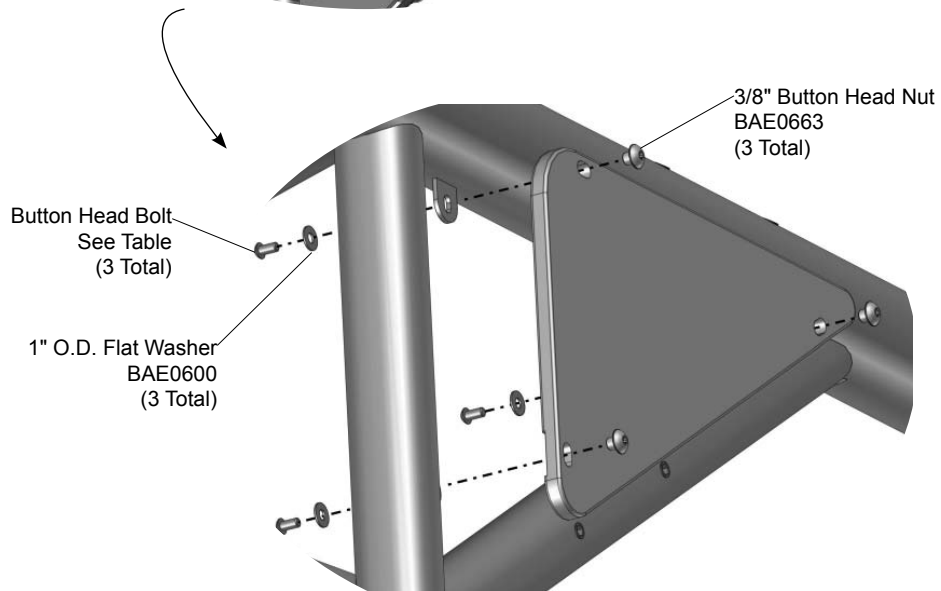

Detail A 
Step 3

Attach the Daughter panel to the Daughter frame.



Installation Instructions

Notes Before You Begin: Do not over tighten bolts during assembly, only snug tighten them until assembly is complete.

Carefully read and understand these installation instructions before you begin.

Step 1: Before attempting to assemble your equipment, please review all installation information carefully. Should you experience any difficulty during the installation process, please call us at the phone number shown on the last page of these instructions.

Step 2: Separate and identify all components and hardware.

Step 3: Attach the Daughter panel to the Daughter frame. See **Detail A**. Position the panel against the tabs on the frame and attach as shown. Fully tighten the connections according to tightening torque specifications.

Torque Specifications:

Bolts and nuts - Snug tighten and then tighten an additional one half turn.



XX0691 - PLAYFORM 7 DAUGHTER SHEET PLASTIC PANEL

PART NO.	DESCRIPTION	QTY.
BAE0600	WASHER - 1" O.D. FLAT	11
BAE0659	BOLT - 3/8"-16 x .75" BUTTON HEAD - SS	11
BAE0663	NUT - 3/8"-16 x 7/16" BUTTON HEAD	11
BAE0922	TOOL - TT 45 L WRENCH	2
BFC3631	SHEET - PLAYFORM 7 (DAUGHTER)	1

XX0692 - PLAYFORM 7 DAUGHTER LAMINATED BAMBOO PANEL

PART NO.	DESCRIPTION	QTY.
BAE0600	WASHER - 1" O.D. FLAT	11
BAE0659	BOLT - 3/8"-16 x .75" BUTTON HEAD - SS	11
BAE0663	NUT - 3/8"-16 x 7/16" BUTTON HEAD	11
BAE0922	TOOL - TT 45 L WRENCH	2
BFC3621	Laminated Bamboo - PLAYFORM 7 (DAUGHTER)	1

XX0693 - PLAYFORM 7 DAUGHTER POLYCARBONATE PANEL

PART NO.	DESCRIPTION	QTY.
BAE0600	WASHER - 1" O.D. FLAT	11
BAE0663	NUT - 3/8"-16 x 7/16" BUTTON HEAD	11
BAE0922	TOOL - TT 45 L WRENCH	2
BFC3627	POLYCARBONATE - PLAYFORM 7 (DAUGHTER)	1
BAE0661	BOLT - 3/8"-16 x .50" BUTTON HEAD - SS	11



The world needs play.[®]

For Customer Service, Call
800-233-8404 or
570-522-9800 OUTSIDE U.S.
 1000 Buffalo Road • Lewisburg, PA 17837
www.playworldsystems.com



Fasteners

- Inspect for loose fasteners.
Tightening torque specifications are:
Bolts and Nuts: Snug tighten and tighten an additional one-half turn.
- If during the maintenance process a bolt needs to be removed from a part or parts, it will be necessary to apply a drop of liquid thread lock / loctite to the bolt before reinstallation.
- Inspect for missing, worn or broken fasteners. If any missing, worn or broken fasteners are found, refer to the installation instructions for proper replacement fastener. If any damage is detected, barricade equipment to prevent use until repair is completed. Contact your sales representative immediately for a replacement part.

Plastic Parts

- Inspect all plastic surfaces for sharp points, cracks or jagged edges. If any damage is detected and is determined to be unsafe, barricade equipment to prevent use until repair is completed. Minor burrs or sharp edges may be removed by using a sharp utility knife or block plane to remove sharp burr.

Replacement Parts

- Refer to your installation instructions to obtain replacement part number.
- Contact your sales representative or call Playworld Systems' Customer Service for a replacement part.

Equipment Maintenance
Playworld Systems®
Models XX0697, XX0698 and XX0699
PlayForm 7
Daughter Sheet Plastic, Laminated
Bamboo
and Polycarbonate Panel



 **PLAYWORLD**
The world needs play.™

For Customer Service, Call
800-233-8404 or
570-522-9800 OUTSIDE U.S.
1000 Buffalo Road • Lewisburg, PA 17837
www.playworldsystems.com

Inspection Form

Preventive Maintenance

... for Safety's Sake!

- Be sure that you are using a copy of this Inspection Form and not your original.
- Use the Inspection Codes listed below and record condition of equipment at time of examination on the Inspection Checklist.
- Document any item from the Inspection Checklist that will require maintenance along with any corrective action on the Maintenance Schedule.
- Be sure to include appropriate dates and signatures on each section to properly document maintenance procedure.

INSPECTION CHECKLIST

	Frequency	Inspection Code	Date	Date Repairs Completed
Inspect plastic parts for damage.	Medium			
Inspect for loose, missing, worn, or broken fasteners.	High			

Inspection Codes

P = Pass **F** = Fail

NA = Not Applicable

Inspector: Name (Please Print) _____ Signature: _____ Date: ___ / ___ / ___

MAINTENANCE SCHEDULE

Item in Question	Description of Problem	Corrective Action	Date

Repairer: Name (Please Print) _____ Signature: _____ Date: ___ / ___ / ___

