

Assembly View (representative structure)

Installation Instructions





Playworld Systems[®] Model XX0703 and
XX0703S

PlayForm 7 Son
In-Ground and Surface Mount

Installation Preparation

Recommended Crew: Four (4) adults
 Installation Time (In-Ground): 7.5 man-hours
 Installation Time (Surface Mount): 6 man-hours
 Concrete Required: 0.36 cubic yard (0,30 cubic meters)
 Use Zone: Refer to Master Drawing
 User Group Age (years): ASTM/CSA: 5-12, EN: 6-14

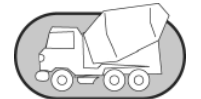
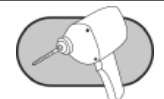
ICON KEY

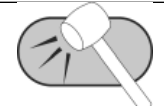
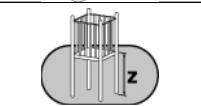
	Fully Tighten Hardware		Add 1 Drop of Thread Locking Adhesive
	Do Not Fully Tighten Hardware		Pour Concrete
	Drill		Dig Footing Holes
	Hammer		Critical Fall Height

Installation Instructions

KEY	
Position	Unit of Measurement
Top #	Inches
Bottom #	[Millimeters]

Footing Diagram

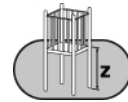
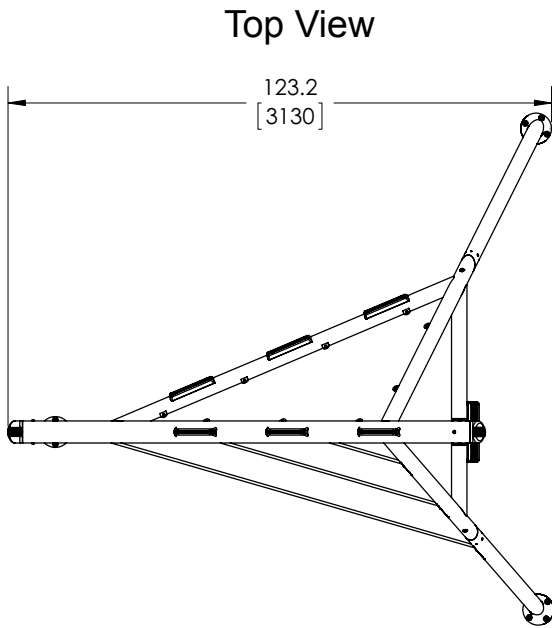

62.4" (1584 mm)

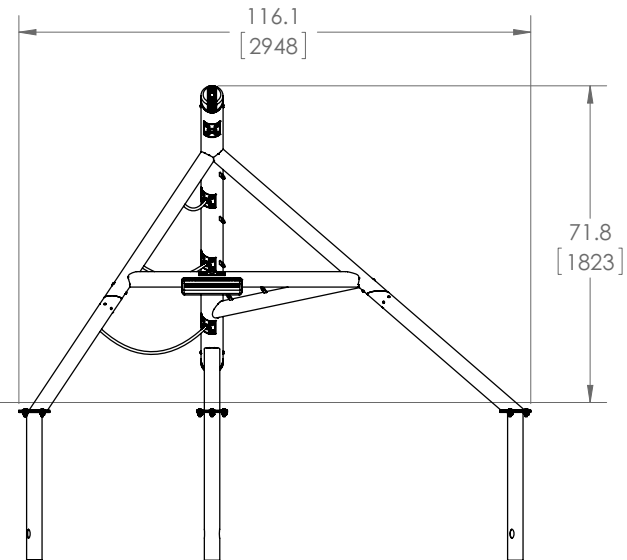
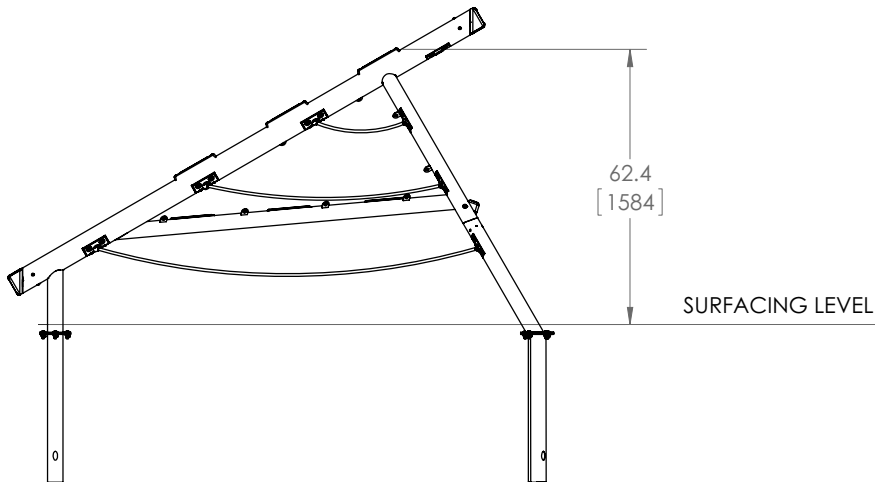
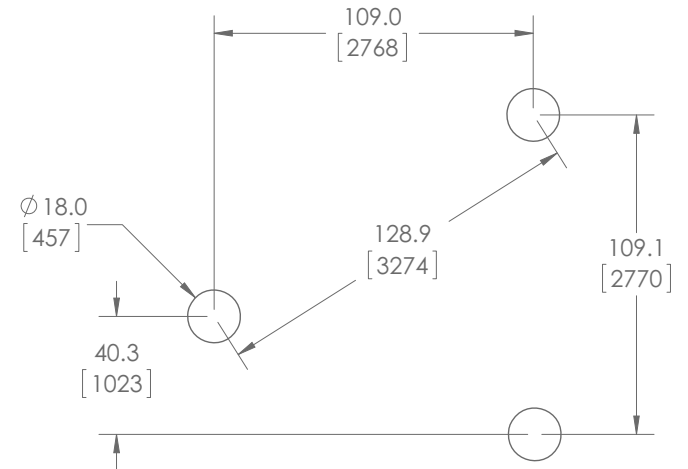

Elevation Views (In-Ground Mount) XX0703



Installation Instructions

KEY	
Position	Unit of Measurement
Top #	Inches
Bottom #	[Millimeters]

Top View

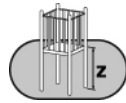
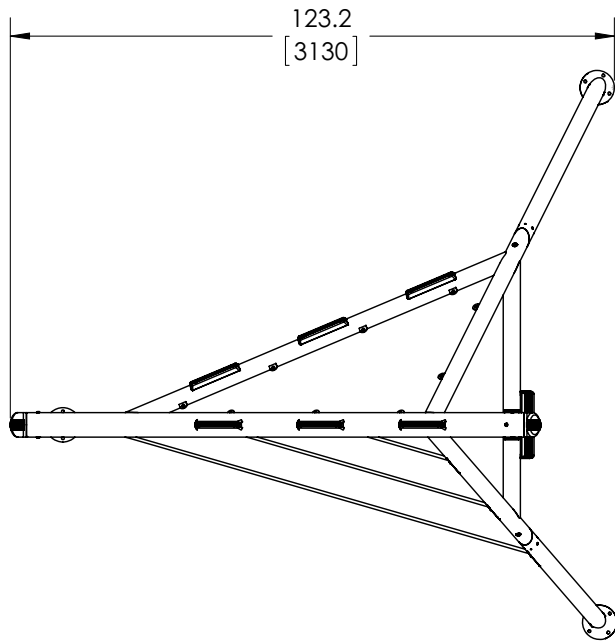

62.4" (1584 mm)

Footing Diagram

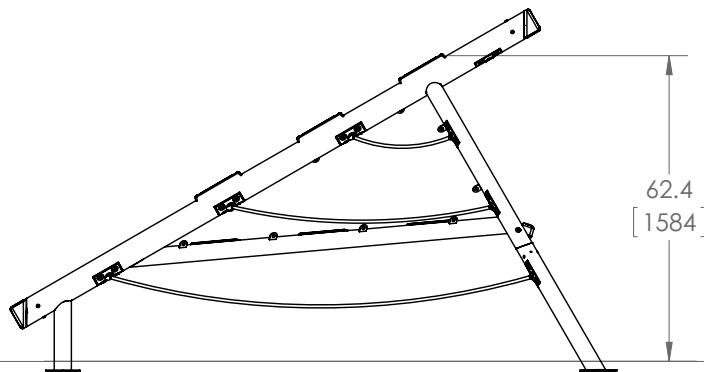
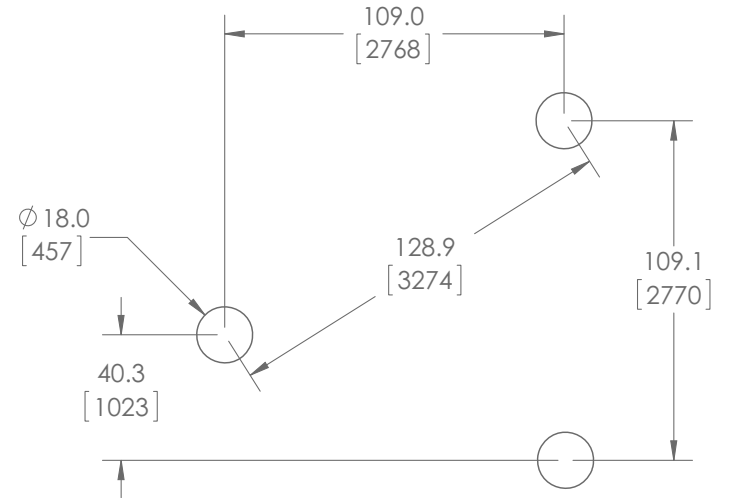

SURFACING LEVEL

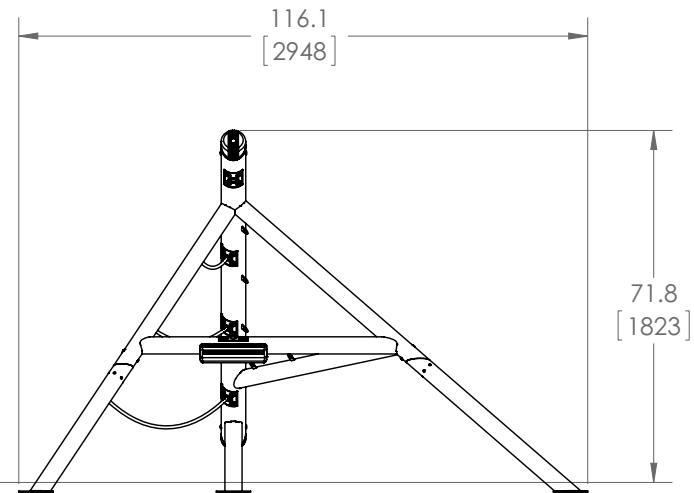

Elevation Views (Surface Mount) XX0703S



Installation Instructions

Follow the details in alphabetical order. For clarification, each detail references the step description. The step descriptions start on page 8.

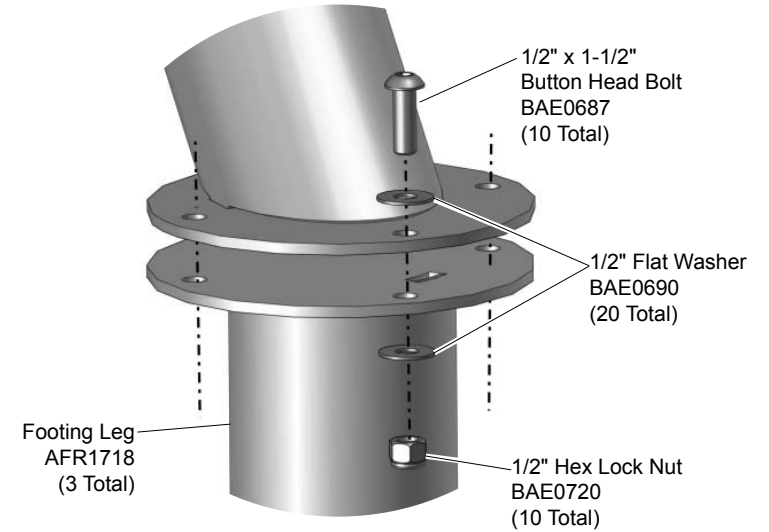
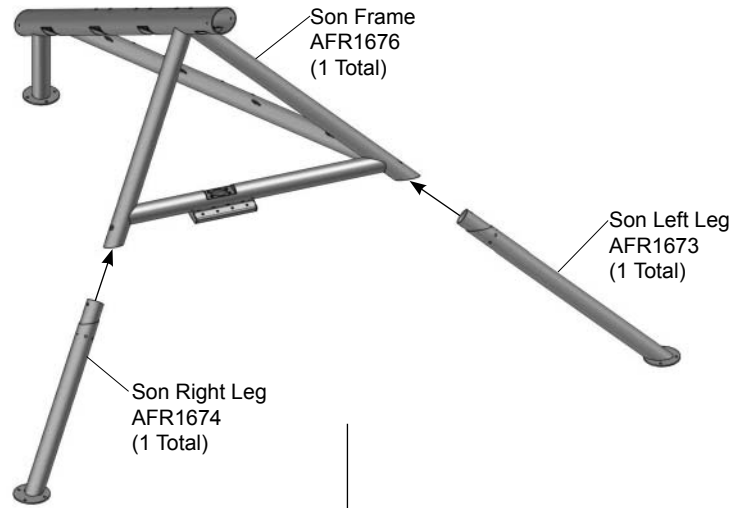

Detail B

Step 5

(In-Ground Mount Only)

Attach the footing legs to the frame assembly.

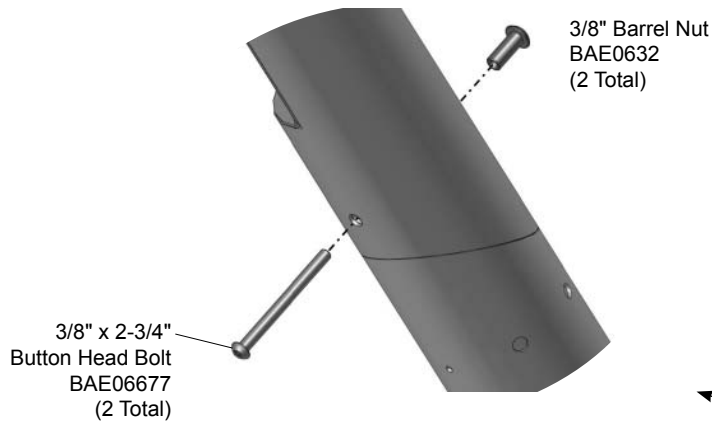

Detail A

Step 4

Attach the left and right legs to the Son frame.

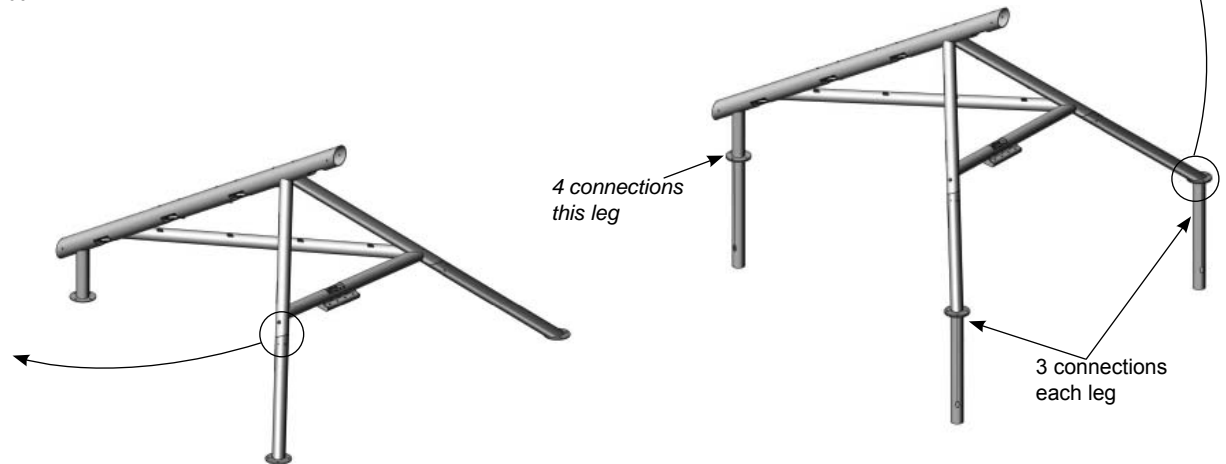

Installation Instructions

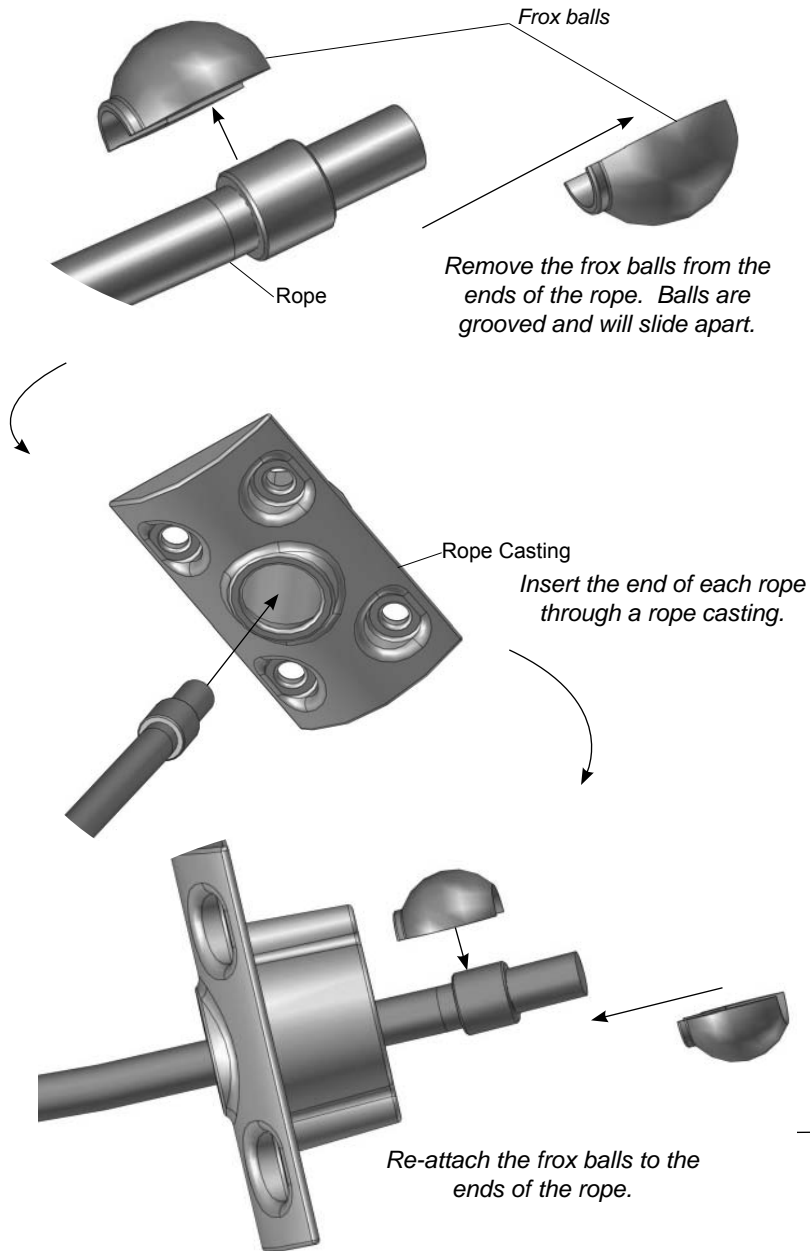

Note: These ends of the rope will connect to the upper post on the Son frame.

Note: These ends of the rope will connect to the lower side of the Son frame and right leg.

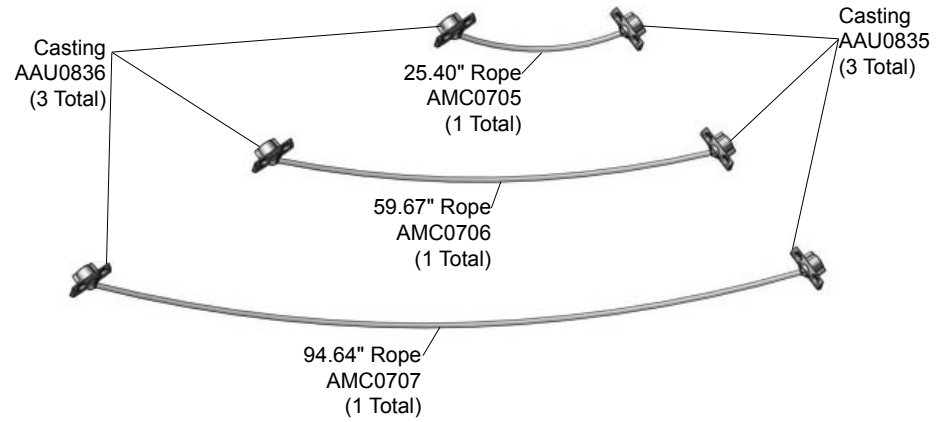

Detail C Step 6

Attach the rope castings to the ends of the ropes.

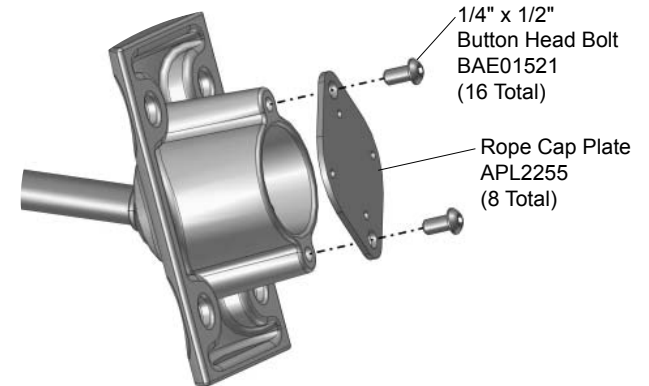

Installation Instructions

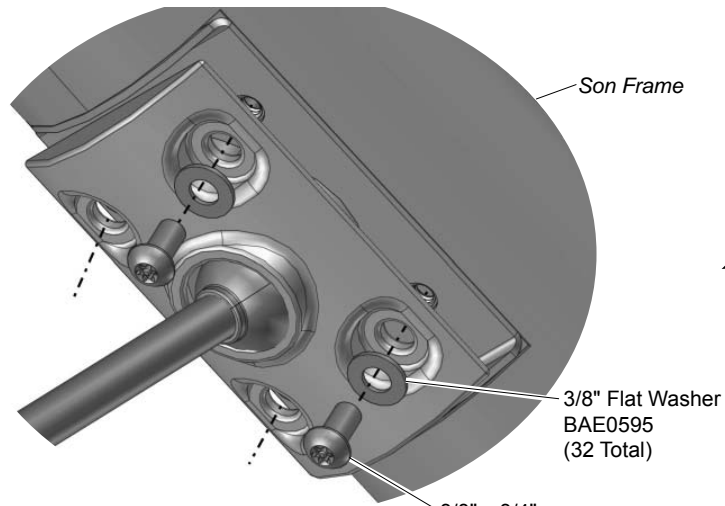

Detail D Step 7

Attach the rope castings to the right leg and the Son frame.

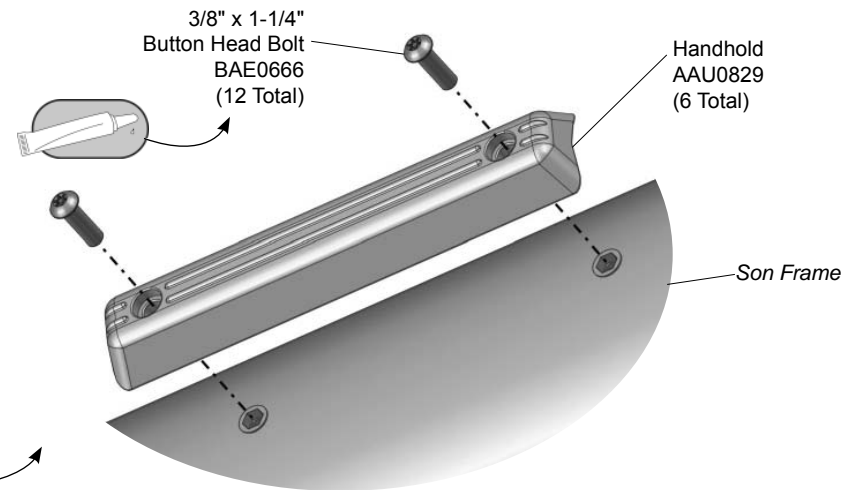
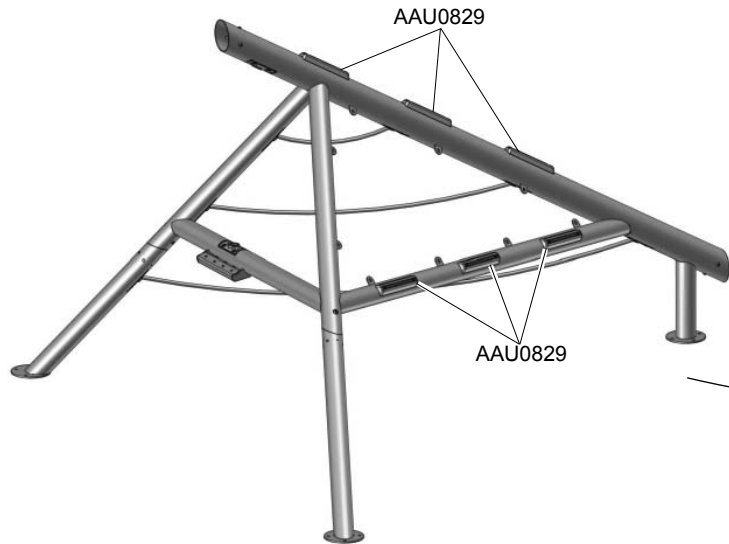
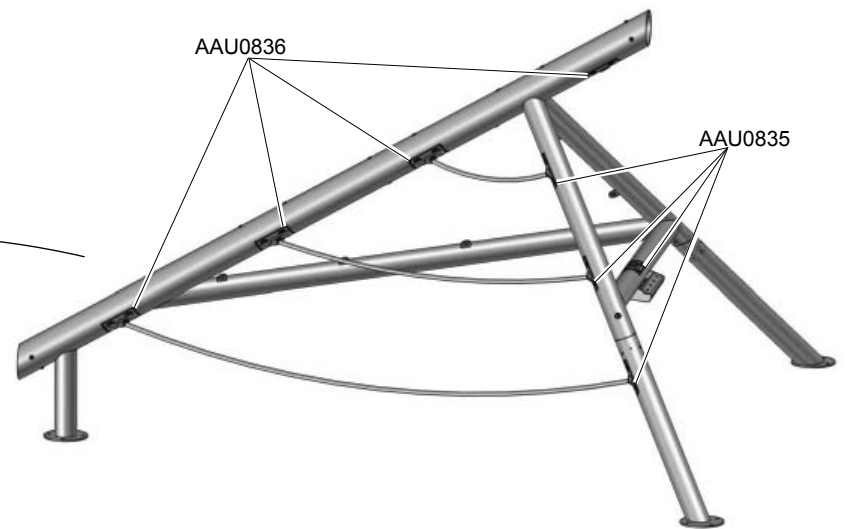

Detail E Step 8

Attach the handholds to the top and side of the Son frame.

Installation Instructions

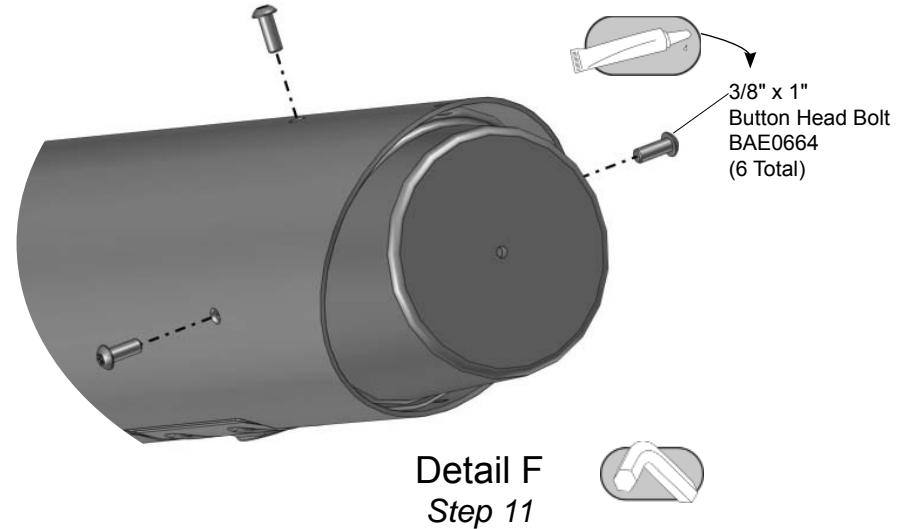
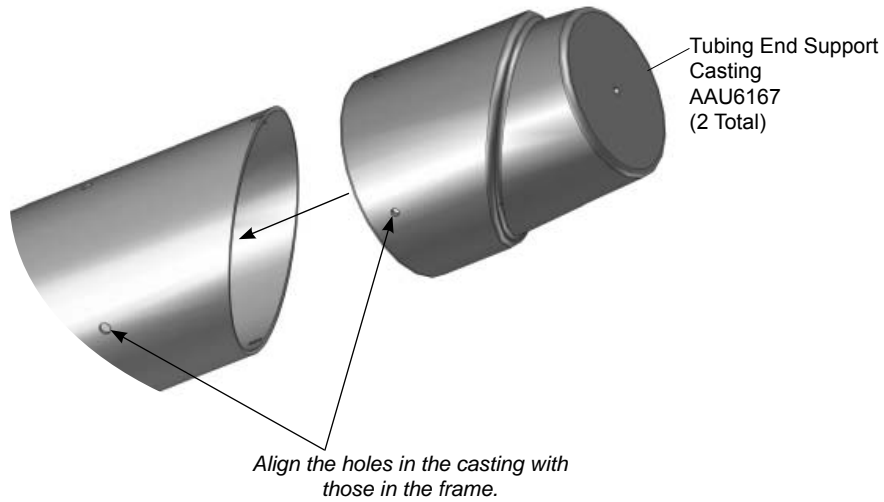

Attach the cap castings to the ends of the Son frame.

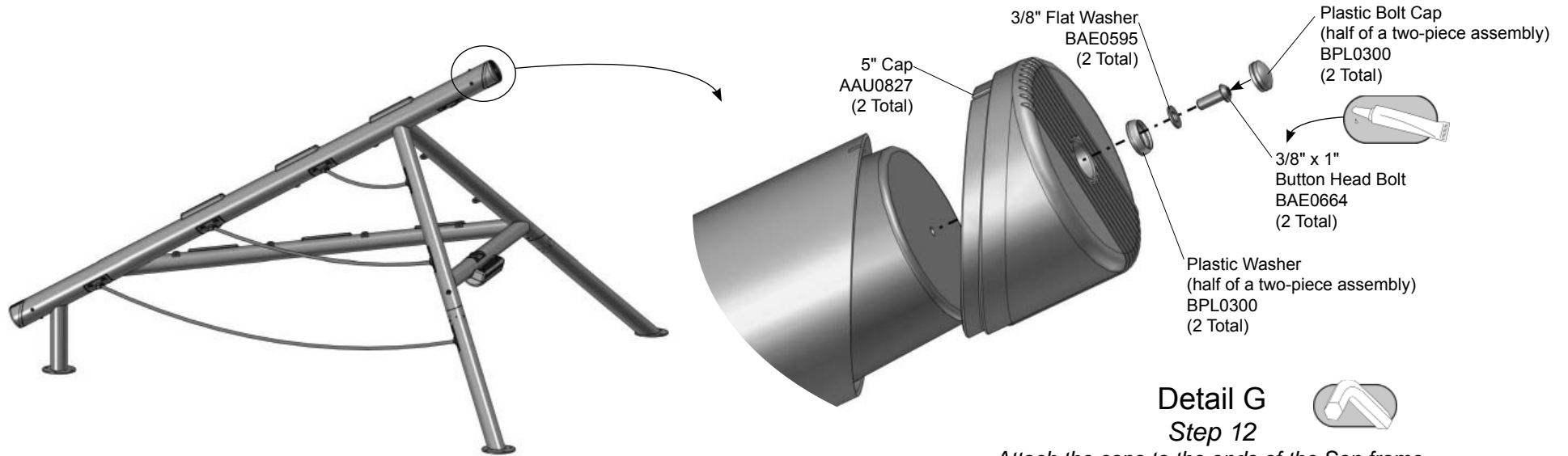

Attach the caps to the ends of the Son frame.

Installation Instructions

Notes Before You Begin: Do not over tighten bolts during assembly, only snug tighten them until assembly is complete. Do not install bolt caps until the structure is completely assembled and properly footed.

Carefully read and understand these installation instructions before you begin.

Step 1: Before attempting to assemble your equipment, please review all installation information carefully. Should you experience any difficulty during the installation process, please call us at the phone number shown on the last page of these instructions.

Step 2: Separate and identify all components and hardware.

Step 3: Excavate or prepare footings as shown in the **Footing Details** in the *Guidelines* at the beginning of this instruction booklet. Use the **Support Post Footing Detail** for the in-ground model.

Step 4: Attach the left and right legs to the Son frame. See **Detail A**. Slide the left and right legs into the Mother frame. Align the holes in the legs with the holes on the Son frame. Select the appropriate hardware, and attach as shown. There is one connection per leg. Fully tighten the connections according to tightening torque specifications.

Step 5 (In-Ground Mount Only): Attach the footing legs to the frame assembly. See **Detail B**. Select the three footing legs, appropriate hardware, and attach as shown. The footing legs attaching to the left and right legs have three hardware connections each. The footing leg attaching to the frame assembly has four hardware connections.

Step 6: Attach the rope castings to the ends of the ropes. See **Detail C**. Remove the frox balls from the ends of the ropes. The balls are grooved and will slide apart. Insert the end of each rope through a rope casting and re-attach the frox balls to the ends of the ropes. Refer to page 5 for the correct part identification of the rope castings on the ropes. Place the rope cap plates on the back of the rope castings, aligning the holes on the plate and casting, apply a drop of thread locking adhesive to the bolt threads, and attach as shown. There are two hardware connections per plate. Fully tighten the connections according to tightening torque specifications.

Step 7: Attach the rope castings to the left and right legs and to the Son frame. See **Detail D**. Align the holes in the casting with the holes on the frame, apply a

drop of thread locking adhesive to the bolt threads, and attach as shown. There are four connections per casting. Refer to page 6 for the correct placement of the castings on the legs and frame.

Step 8: Attach the small handholds to the top and side of the Son frame. See **Detail E**. Select the handholds and the appropriate hardware, apply a drop of thread locking adhesive to the bolt threads, and attach as shown. There are two hardware connections per handhold. Fully tighten the connections according to tightening torque specifications.

Step 9: Finish assembling the other components and attaching any other belts or ropes between component.

Final Details.

Step 10: Plumb and level the component. Tighten **all** fasteners. Fully tighten all fasteners according to tightening torque specifications.

Torque Specifications:

Bolts and nuts - Snug tighten and then tighten an additional one half turn.

(In-Ground Mount Only): Plumb and level entire component. Fully tighten **all** fasteners according to tightening torque specifications. Block and brace for concrete. Pour concrete after all equipment has been assembled. Allow 72 hours for concrete to completely cure.

(Surface Mount Only): Plumb and level entire component. Fully tighten all fasteners according to tightening torque specifications. Bolt down all surface mount supports in accordance with specifications provided by your registered structural engineer.

Important Note: Surface mount hardware is not supplied. Customer is responsible for concrete base and for providing surface mount hardware as specified by a registered structural engineer for each specific project application.

Step 11: Attach the end support castings to the ends of the Son frame. See **Detail F**. Insert the end support castings into the ends of the 5" frame, aligning the holes in the castings with those in the frame. Select the appropriate hardware, attach a drop of thread locking adhesive to the bolt threads, and attach as shown. There are three hardware connections per casting. Fully tighten the connections according to tightening torque specifications.

Installation Instructions

Step 12: Attach the caps to the ends of the Son frame. See **Detail G**. Place the 5" caps on the ends of the Son frame (the longer side of the cap should be on the bottom when placing in the frame), select the appropriate hardware, apply a drop of thread locking adhesive to the bolt threads, and attach as shown. There is one hardware connection per cap. Fully tighten the connections according to tightening torque specifications.

Step 13: Select plastic caps and press over the plastic flanged washers. See **Detail G**.

Note: The plastic caps install easier when they are warm.

Step 14: For areas complying with ASTM standard F1487 or the CSA Z-614, apply the age appropriate label to the component at eye level.

ZZXX0703 - PLAYFORM 7 SON IN-GROUND MOUNT

PART NO.	DESCRIPTION	QTY.
AAU0827	5" PLAYFORM 7 CAP	2
AAU0829	SMALL MOHAWK PLAYFORM 7	6
AAU0835	ROPE CASTING FOR 3.50" TUBING	4
AAU0836	ROPE CASTING FOR 5.00" TUBING	4
AAU0839	COVER CASTING FOR 12.00" BELT 3.50" O.D. TUBING	1
AAU6167	CASTING - 5" TUBING CAP SUPPORT	2
AFR1673	FRAME - SON LEG (LEFT)	1
AFR1674	FRAME - SON LEG (RIGHT)	1
AFR1676	FRAME - SON	1
AFR1718	FRAME -3.50" O.D. FOOTING LEG	3
AMC0705	ROPE - .63" O.D. x 25.40"	1
AMC0706	ROPE - .63" O.D. x 59.67"	1
AMC0707	ROPE - .63" O.D. x 94.64"	1
APL2255	PLATE - ROPE CAP	8
APL2265	PLATE - 6.75" x 1.50" x 7 GA	1
APL2275	PLATE - 11.50" x 1.50" x 12 GA	1
BAD0085	THREAD LOCKING ADHESIVE	3
BAE0595	WASHER - 3/8" SAE FLAT	42
BAE0632	NUT - 3/8"-16 x 1.25" BARREL w/PATCH	2
BAE0659	BOLT - 3/8"-16 x .75" BUTTON HEAD - S.S.	32
BAE0664	BOLT - 3/8"-16 x 1.00" BUTTON HEAD - S.S.	8
BAE0666	BOLT - 3/8"-16 x 1.25" BUTTON HEAD - S.S.	16
BAE0687	BOLT - 1/2"-13 x 1.50" BUTTON HEAD - S.S.	10
BAE0690	WASHER - .531" I.D. x 1.250" O.D. x .060" THICK	20
BAE0720	NUT - 1/2"-13 LOCK	10
BAE0900	WRENCH - 5/32" SHORT HEX KEY	1
BAE0906	TOOL - 5/16" SHORT HEX KEY WRENCH	1
BAE0922	TOOL - TT 45 L WRENCH	2
BAE01521	BOLT - 1/4"-20 x .50" BUTTON HEAD - S.S.	16
BAE06645	BOLT - 3/8"-16 x 1.50" BUTTON HEAD - S.S.	4
BAE06677	BOLT - 3/8"-16 x 2.75" BUTTON HEAD - S.S.	2
BPL0300	CAP - 3/8" BOLT	2
ALB0025	LABEL - AGE APPROPRIATE SHEET	1



ZZXX0703S - PLAYFORM 7 SON SURFACE MOUNT

PART NO.	DESCRIPTION	QTY.
AAU0827	5" PLAYFORM 7 CAP	2
AAU0829	SMALL MOHAWK PLAYFORM 7	6
AAU0835	ROPE CASTING FOR 3.50" TUBING	4
AAU0836	ROPE CASTING FOR 5.00" TUBING	4
AAU0839	COVER CASTING FOR 12.00" BELT 3.50" O.D. TUBING	1
AAU6167	CASTING - 5" TUBING CAP SUPPORT	2
AFR1673	FRAME - SON LEG (LEFT)	1
AFR1674	FRAME - SON LEG (RIGHT)	1
AFR1676	FRAME - SON	1
AMC0705	ROPE - .63" O.D. x 25.40"	1
AMC0706	ROPE - .63" O.D. x 59.67"	1
AMC0707	ROPE - .63" O.D. x 94.64"	1
APL2255	PLATE - ROPE CAP	8
APL2265	PLATE - 6.75" x 1.50" x 7 GA	1
APL2275	PLATE - 11.50" x 1.50" x 12 GA	1
BAD0085	THREAD LOCKING ADHESIVE	3
BAE0595	WASHER - 3/8" SAE FLAT	42
BAE0632	NUT - 3/8"-16 x 1.25" BARREL w/PATCH	2
BAE0659	BOLT - 3/8"-16 x .75" BUTTON HEAD - S.S.	32
BAE0664	BOLT - 3/8"-16 x 1.00" BUTTON HEAD - S.S.	8
BAE0666	BOLT - 3/8"-16 x 1.25" BUTTON HEAD - S.S.	16
BAE0900	WRENCH - 5/32" SHORT HEX KEY	1
BAE0922	TOOL - TT 45 L WRENCH	2
BAE01521	BOLT - 1/4"-20 x .50" BUTTON HEAD - S.S.	16
BAE06645	BOLT - 3/8"-16 x 1.50" BUTTON HEAD - S.S.	4
BAE06677	BOLT - 3/8"-16 x 2.75" BUTTON HEAD - S.S.	2
BPL0300	CAP - 3/8" BOLT	2
ALB0025	LABEL - AGE APPROPRIATE SHEET	1



The world needs play.™

For Customer Service, Call
800-233-8404 or
570-522-9800 OUTSIDE U.S.

1000 Buffalo Road • Lewisburg, PA 17837
www.playworldsystems.com



This page is
intentionally left blank.



Fasteners

- Inspect for loose fasteners.
Tightening torque specifications are:
Bolts and Nuts: Snug tighten and tighten an additional one-half turn.
- If during the maintenance process a bolt needs to be removed from a part or parts, it will be necessary to apply a drop of liquid thread lock / loctite to the bolt before reinstallation.
- Inspect for missing, worn or broken fasteners. If any missing, worn or broken fasteners are found, refer to the installation instructions for proper replacement fastener. If any damage is detected, barricade equipment to prevent use until repair is completed. Contact your sales representative immediately for a replacement part.

Castings

- Inspect the aluminum castings to insure they are properly secured to the component.
- Visually inspect the castings for cracks or breakage. If any damage is detected, barricade the equipment to prevent use until repair is completed. Contact your sales representative immediately for a replacement part.

Welds

- Inspect all welded joints. If any broken welds are detected, barricade equipment to prevent use until repair is completed. Contact your sales representative immediately for a replacement part.

Finish

- Inspect metal parts for finish damage.
To repair painted surfaces, sand damaged area with sandpaper and wipe clean. Mask area and paint with primer and allow to dry. Paint primed area with color-matching paint and allow to dry. Recoat area with color-matching paint if required. Drying time is approximately 8 hours between coats.

Footings

- Inspect component to be solid in footing and secure. If any damage is detected, barricade equipment to prevent use until repair is completed.

Surfacing

- Refer to the specific surfacing maintenance detail sheet for additional information.

Replacement Parts

- Refer to your installation instructions to obtain replacement part number.
- Contact your sales representative or call Playworld Systems' Customer Service for a replacement part.

Equipment Maintenance Playworld Systems® Model XX0703 and XX0703S PlayForm 7 Son



Inspection Form

- Be sure that you are using a copy of this Inspection Form and not your original.
- Use the Inspection Codes listed below and record condition of equipment at time of examination on the Inspection Checklist.
- Document any item from the Inspection Checklist that will require maintenance along with any corrective action on the Maintenance Schedule.
- Be sure to include appropriate dates and signatures on each section to properly document maintenance procedure.

Preventive Maintenance
... for Safety's Sake!

INSPECTION CHECKLIST

	Frequency	Inspection Code	Date	Date Repairs Completed
Inspect metal parts for structural and finish damage.	Medium			
Inspect for loose, missing, worn, or broken fasteners.	High			
Inspect footing to insure support is secure and footing is not damaged.	Low			
Inspect surfacing to insure proper depth and distribution.	High			

Inspection Codes
P = Pass F = Fail
NA = Not Applicable

Inspector: Name (Please Print) _____ Signature: _____ Date: ___ / ___ / ___

MAINTENANCE SCHEDULE

Item in Question	Description of Problem	Corrective Action	Date

Repairer: Name (Please Print) _____ Signature: _____ Date: ___ / ___ / ___

