



Assembly View

## Installation Instructions

Playworld Systems<sup>®</sup> Model XX0705





PlayForm 7

Father To Mother Belts And Handle

### Installation Preparation

Recommended Crew: ..... Two (2) adults  
 Installation Time: ..... 6 man-hours  
 Use Zone: ..... Refer to the layout drawing  
 User Group Age (years): ..... ASTM/CSA: 5-12, EN: 6-14

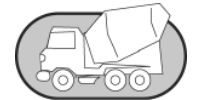
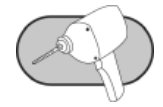
#### ICON KEY

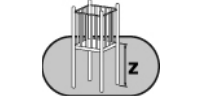
	Fully Tighten Hardware		Add 1 Drop of Thread Locking Adhesive
	Do <b>Not</b> Fully Tighten Hardware		Pour Concrete
	Drill		Dig Footing Holes
	Hammer		Critical Fall Height

# Installation Instructions

Follow the details in alphabetical order. For clarification, each detail references the step description. The step descriptions start on page 7.

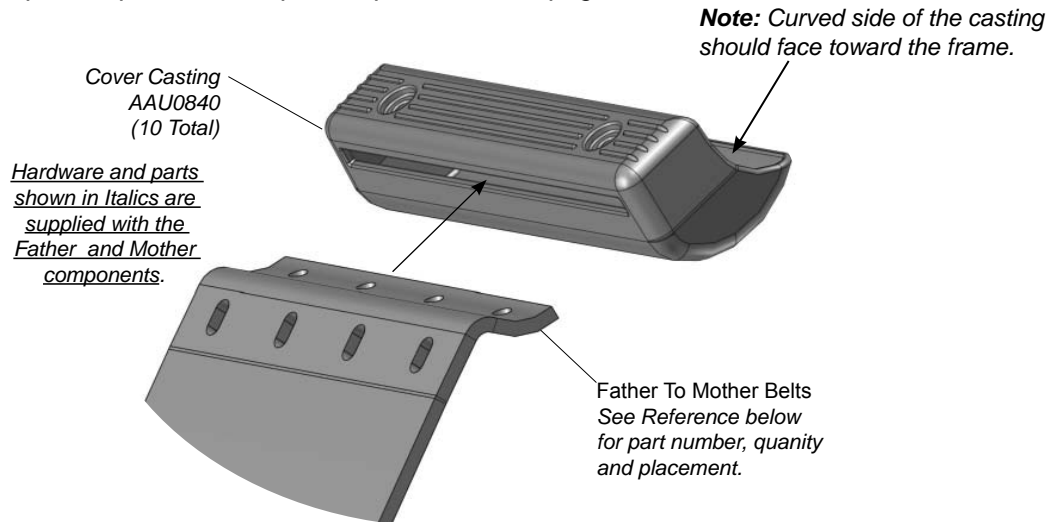

## Detail A-1 Step 3

Place a cover casting onto each end of the Father to Mother belts.

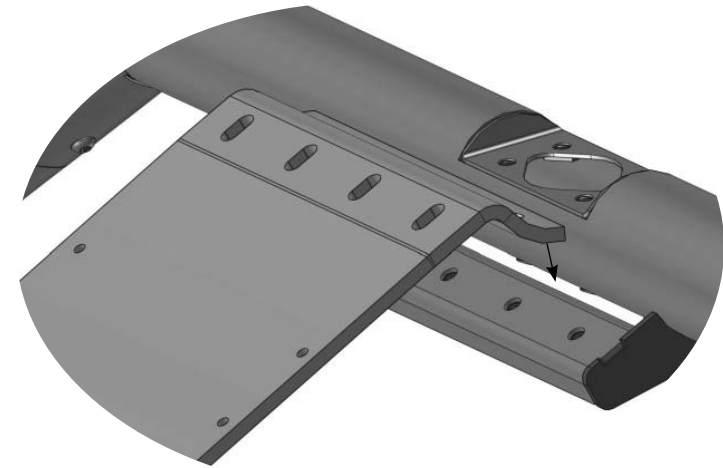

## Detail A-2 Step 3

Insert the Father to Mother belts into the brackets on the Father and Mother frames.

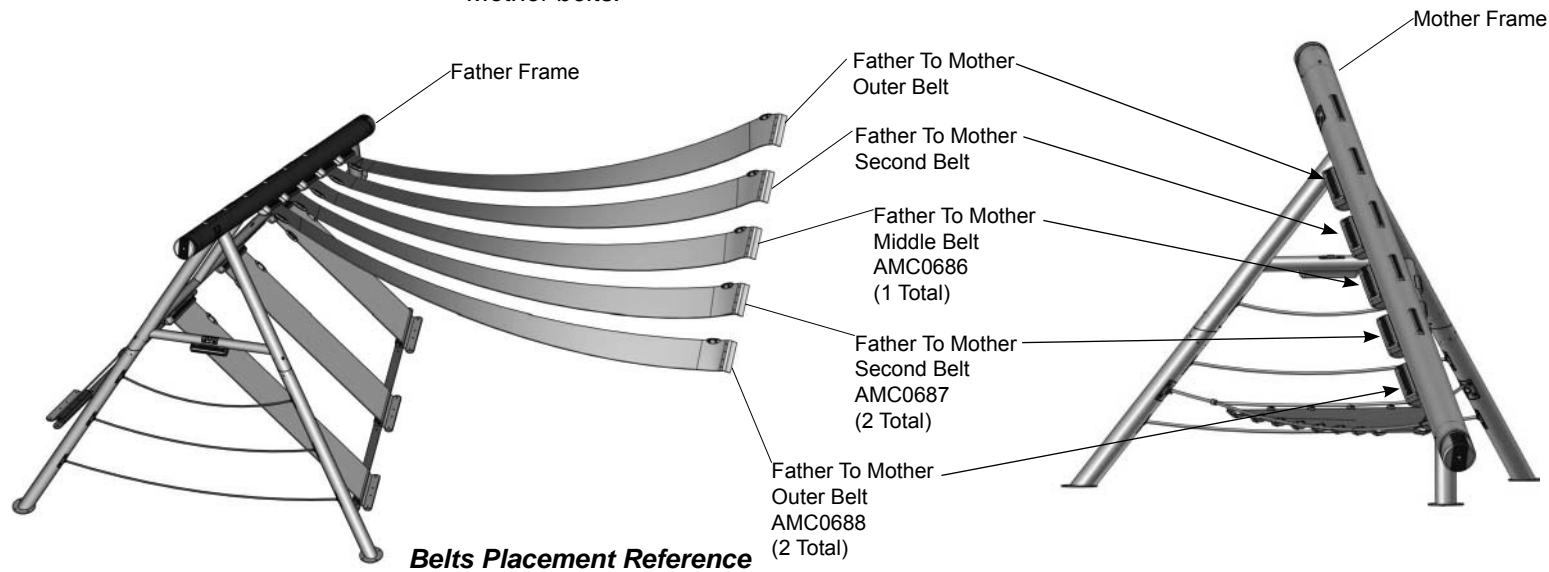

# Installation Instructions

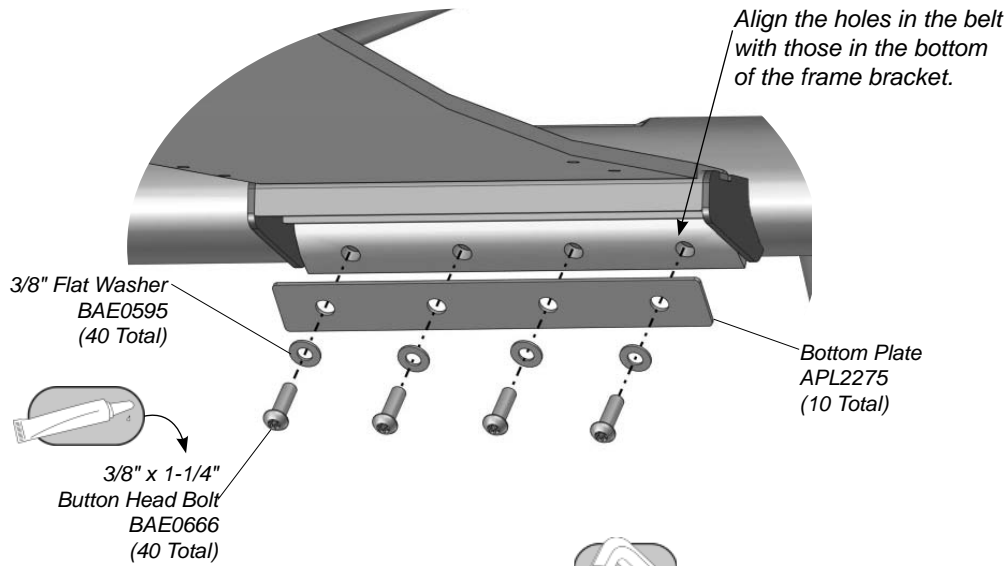

## Detail A-3 Step 3

Attach each end of the belt to the underside of each frame bracket.

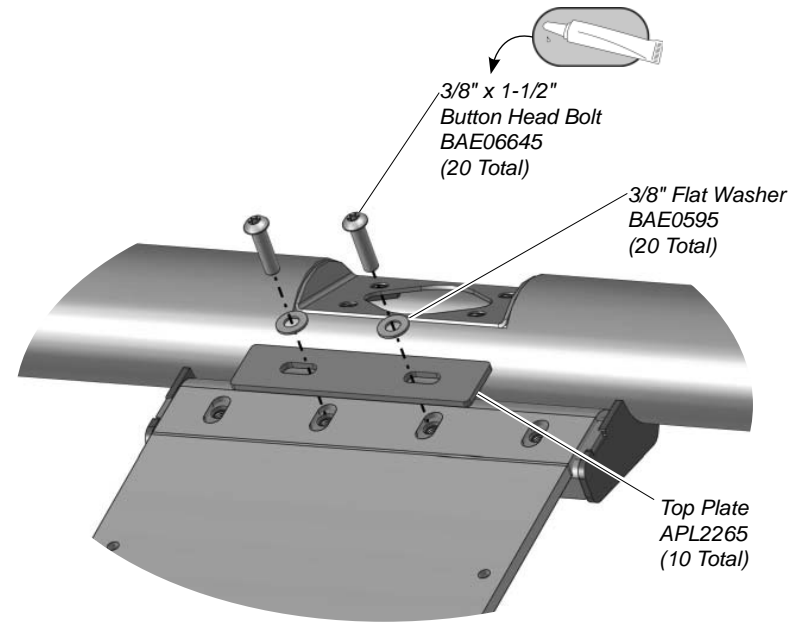

## Detail A-4 Step 3

Attach each end of the belt to the top side of each frame bracket.

# Installation Instructions

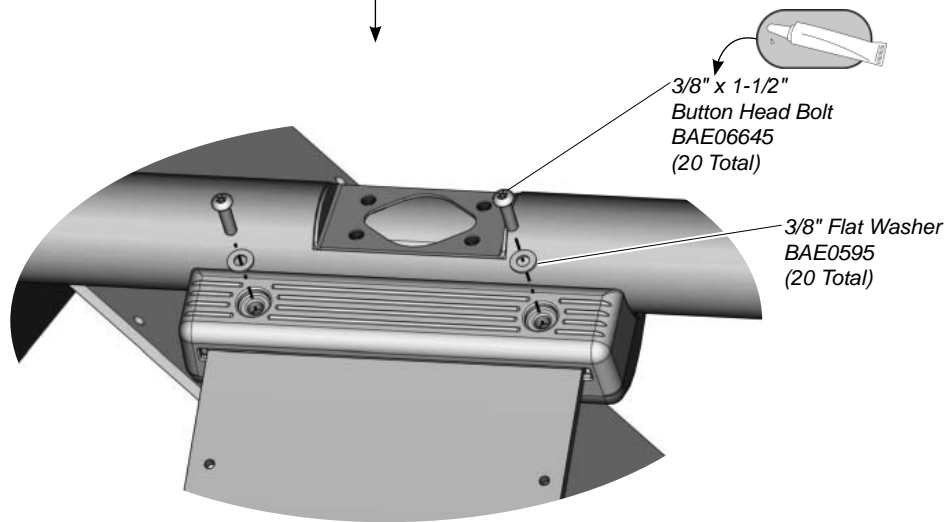
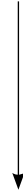
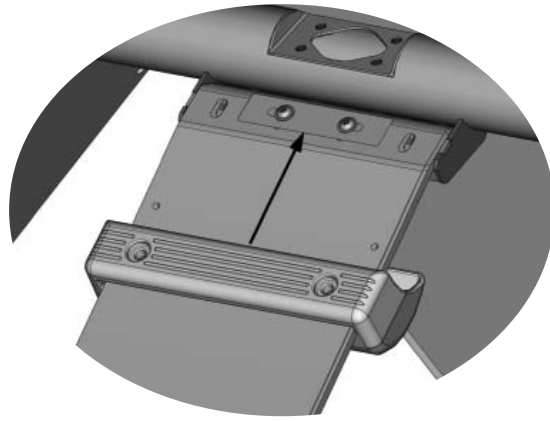

**Detail A-5**  
Step 3



Attach the cover castings to the frame brackets.

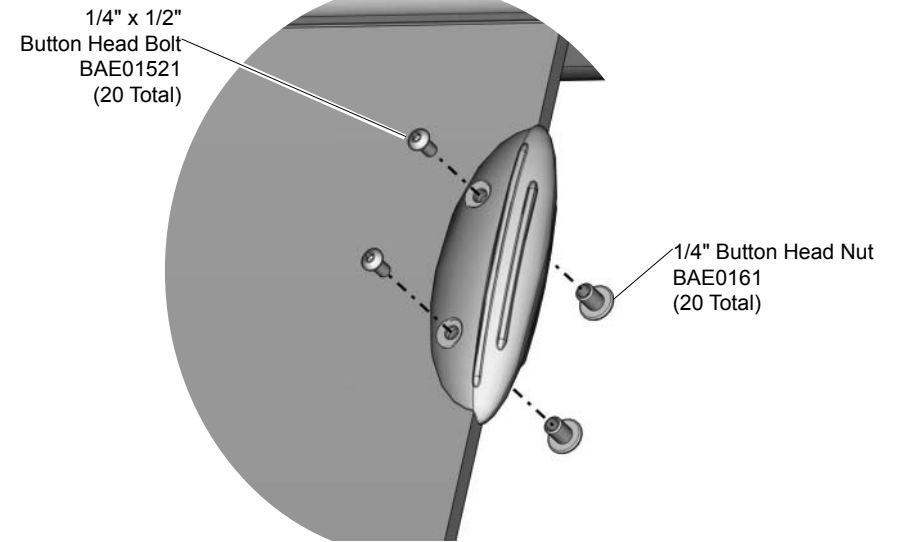
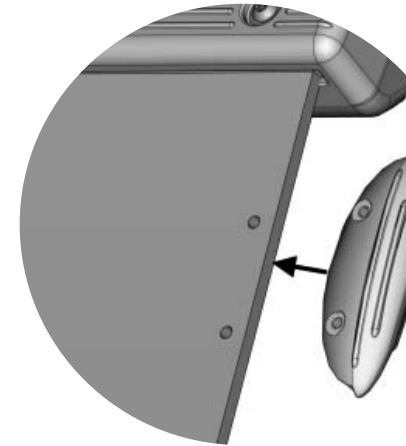

**Detail B**  
Step 4



Attach the belt handles to the belts.

# Installation Instructions

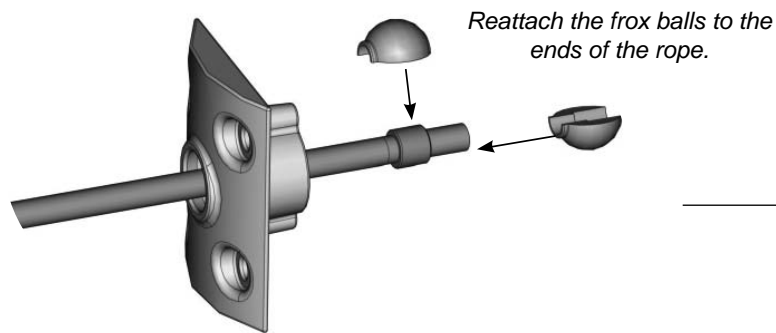
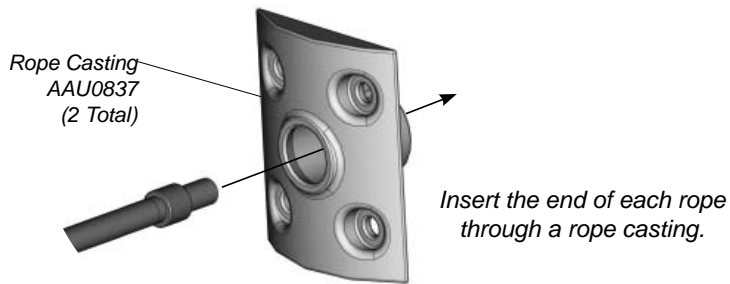
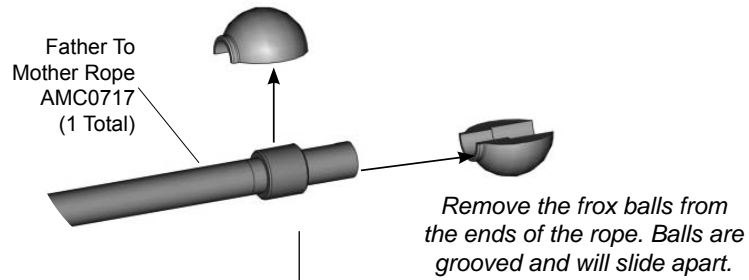

Detail C  
Step 5

Attach the rope castings to the ends of the Father to Mother rope.

**Note:** this end of the rope will connect to the Father frame.



**Note:** this end of the rope will connect to the Mother frame.

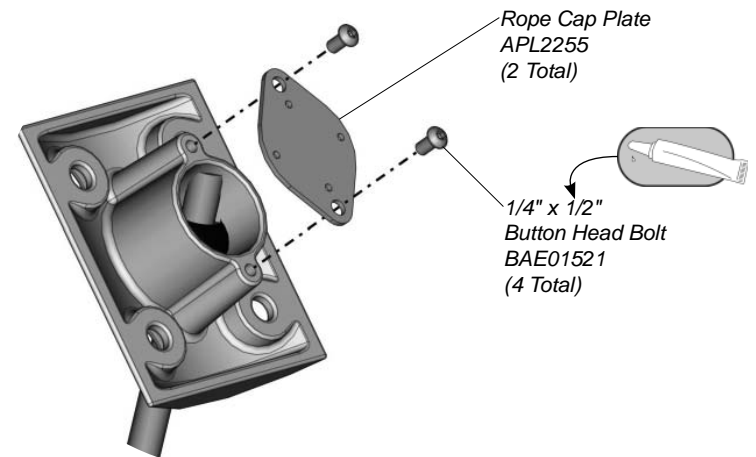

# Installation Instructions

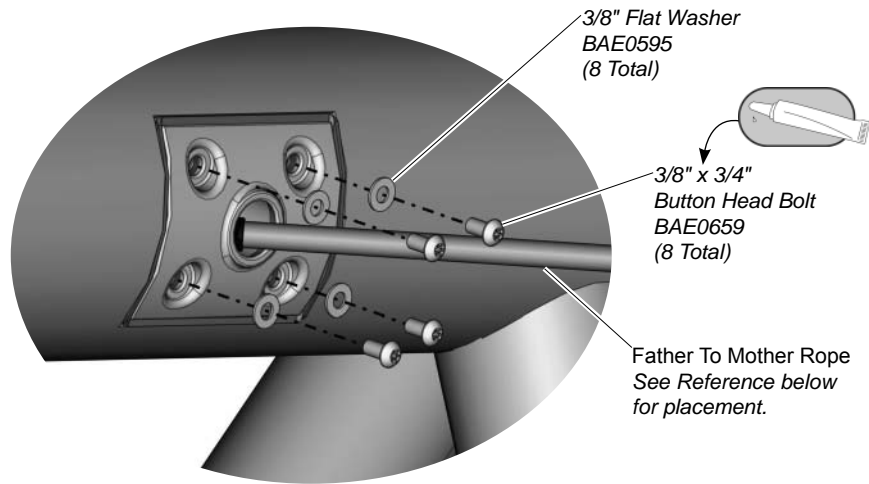

## Detail D Step 6



Attach the Father to Mother rope to the Father and Mother frames.

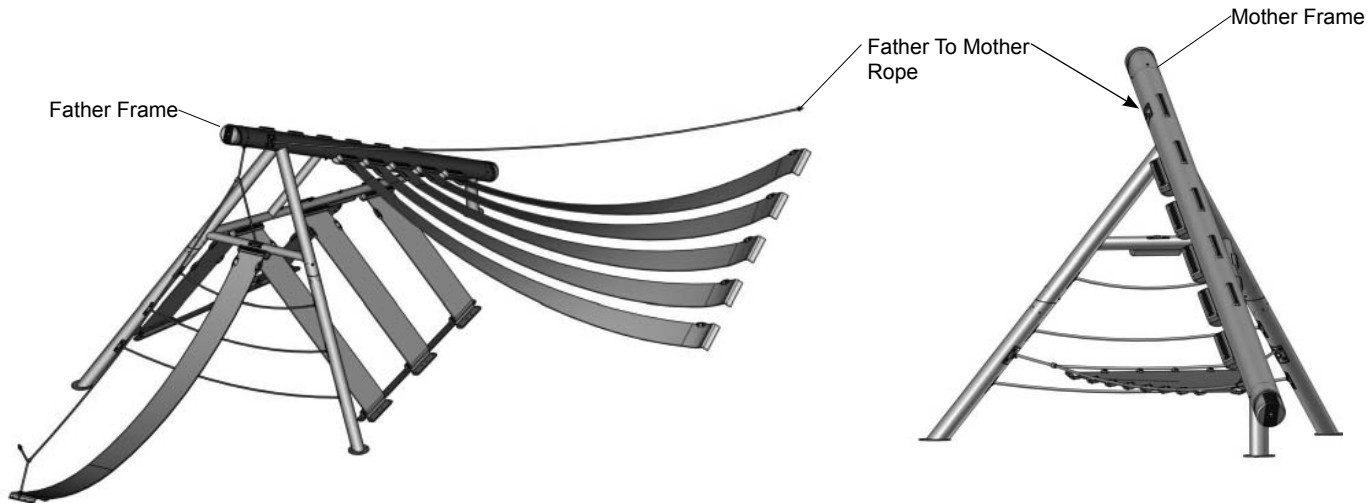

**Rope Placement Reference**

# Installation Instructions

**Notes Before You Begin:** Do not over tighten bolts during assembly, only snug tighten them until assembly is complete.

**Carefully read and understand these installation instructions before you begin.**

**Step 1:** Before attempting to assemble your equipment, please review all installation information carefully. Should you experience any difficulty during the installation process, please call us at the phone number shown on the last page of these instructions.

**Step 2:** Separate and identify all components and hardware.

**Step 3:** Attach the belts to the Father and Mother frames. See **Details A-1 through A5 and Belts Placement Reference**. Place a cover casting onto each end of the Father to Mother belts. Ensure the curved side of the casting is facing the frame bracket. Insert the end of each belt into the appropriate bracket on the Father and Mother frames. Apply a drop of thread locking adhesive to the bolt threads and attach the end of the belts to the *underside* of the frame brackets as shown. Apply a drop of thread locking adhesive to the bolt threads and attach the end of the belts to the top side of the frame brackets as shown. Fully tighten the connections, both underneath and on top of the bracket, according to tightening torque specifications. Slide the cover casting over top of the frame bracket, apply a drop of thread locking adhesive to the bolt threads and attach as shown. Fully tighten those connections according to tightening torque specifications.

**Torque Specifications:**

*Bolts and nuts* - Snug tighten and then tighten an additional one half turn.

**Step 4:** Attach the belt handles to the belts. See **Detail B**. Position each handle onto the edge of the belt and align with the set of holes along the side of the belt and attach as shown. Fully tighten the connections according to tightening torque specifications.

**Step 5:** Attach the rope castings to the ends of the Father To Mother rope. See **Detail C**. Remove the frox balls from the ends of the rope. Balls are grooved and will slide apart. Insert the each end of the ropes through a casting and reattach the frox balls. Pull the rope tight in the casting, apply a drop of thread locking adhesive to the bolt threads and attach the rope cap plate to the casting as shown. Fully tighten the connections according to tightening torque specifications.

**Step 6:** Attach the Father to Mother rope to the Father and Mother frames. See **Detail D and Rope Placement Reference**. Position the rope castings against the Father and Mother frames, apply a drop of thread locking adhesive to the bolt threads and attach as shown. Fully tighten those connections according to tightening torque specifications.



## XX0705 - PLAYFORM 7 FATHER TO MOTHER BELTS AND HANDLE

PART NO.	DESCRIPTION	QTY.
AAU0834	BELT HANDLE	10
AMC0686	BELT - MOTHER TO FATHER - MIDDLE	1
AMC0687	BELT - FATHER TO MOTHER - SECOND	2
AMC0688	BELT - FATHER TO MOTHER - OUTER	2
AMC0717	ROPE - .63" O.D. x 224.00" DAD TO MOM	1
BAE0161	NUT - 1/4"-20 x 7/16" BUTTON HEAD	20
BAE0900	WRENCH - 5/32" SHORT HEX KEY	1
BAE0902	TOOL - 7/32" SHORT HEX KEY WRENCH	1
BAE01521	BOLT - 1/4"-20 x .50" BUTTON HEAD - SS	20



**PLAYWORLD**  
The world needs play.  
For Customer Service, Call  
**800-233-8404** or  
**570-522-9800** OUTSIDE U.S.  
1000 Buffalo Road • Lewisburg, PA 17837  
[www.playworldsystems.com](http://www.playworldsystems.com)





#### Fasteners

- Inspect for loose fasteners.  
Tightening torque specifications are:  
Bolts and Nuts: Snug tighten and tighten an additional one-half turn.
- If during the maintenance process a bolt needs to be removed from a part or parts, it will be necessary to apply a drop of liquid thread lock / loctite to the bolt before reinstallation.
- Inspect for missing, worn or broken fasteners. If any missing, worn or broken fasteners are found, refer to the installation instructions for proper replacement fastener. If any damage is detected, barricade equipment to prevent use until repair is completed. Contact your sales representative immediately for a replacement part.

#### Castings

- Inspect the aluminum castings to insure they are properly secured to the component.
- Visually inspect the castings for cracks or breakage. If any damage is detected, barricade the equipment to prevent use until repair is completed. Contact your sales representative immediately for a replacement part.

#### Rope

- Inspect the rope for any fraying, wear or loose connectors.

#### Mats

- Inspect the mats for any tears or loose connectors.

#### Replacement Parts

- Refer to your installation instructions to obtain replacement part number.
- Contact your sales representative or call Playworld Systems' Customer Service for a replacement part.

## Equipment Maintenance Playworld Systems® Model XX0705 PlayForm 7 Father To Mother Belts And Handle



 **PLAYWORLD**  
The world needs play.™

For Customer Service, Call  
**800-233-8404** or  
**570-522-9800** OUTSIDE U.S.  
1000 Buffalo Road • Lewisburg, PA 17837  
[www.playworldsystems.com](http://www.playworldsystems.com)

# Inspection Form

## Preventive Maintenance

**... for Safety's Sake!**

- Be sure that you are using a copy of this Inspection Form and not your original.
- Use the Inspection Codes listed below and record condition of equipment at time of examination on the Inspection Checklist.
- Document any item from the Inspection Checklist that will require maintenance along with any corrective action on the Maintenance Schedule.
- Be sure to include appropriate dates and signatures on each section to properly document maintenance procedure.

### INSPECTION CHECKLIST

	Frequency	Inspection Code	Date	Date Repairs Completed
Inspect the rope for damage.	Medium			
Inspect the mats for damage.	High			
Inspect for loose, missing, worn, or broken fasteners.	High			

**Inspection Codes**

**P** = Pass    **F** = Fail

**NA** = Not Applicable

Inspector: Name (Please Print) \_\_\_\_\_ Signature: \_\_\_\_\_ Date: \_\_\_ / \_\_\_ / \_\_\_

### MAINTENANCE SCHEDULE

Item in Question	Description of Problem	Corrective Action	Date

Repairer: Name (Please Print) \_\_\_\_\_ Signature: \_\_\_\_\_ Date: \_\_\_ / \_\_\_ / \_\_\_