

# HAGS®

## Omega Swing Base Module Two Seater MASW73159

SW73159

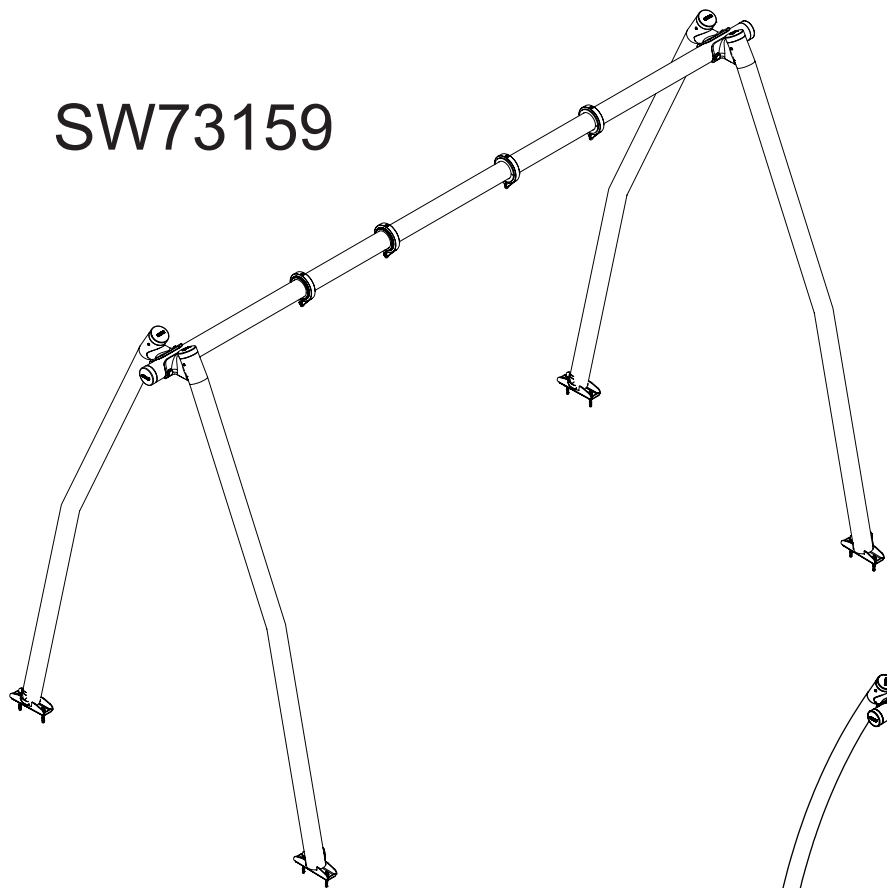

OM

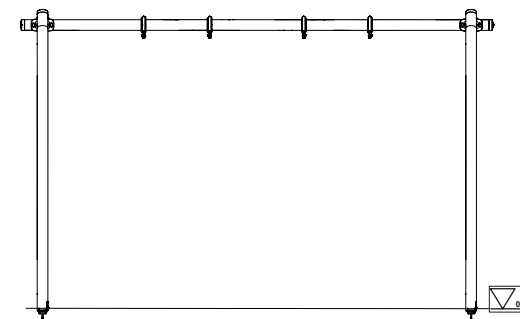

SW51357

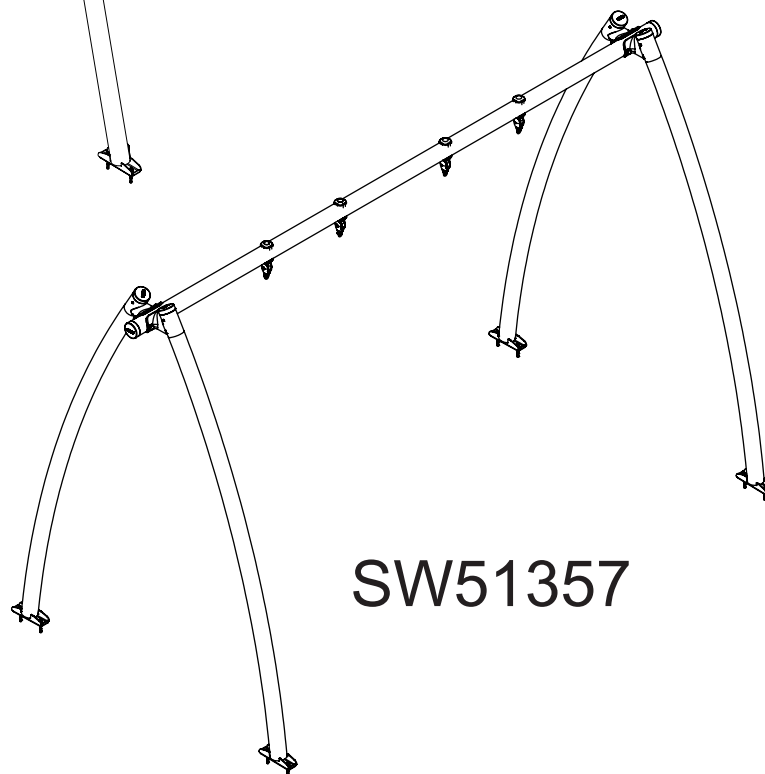

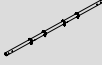

1	SW72298		1x Ø88.9 x 3870mm	31.87kg
---	---------	--	-------------------	---------

2	SW51047		4x Ø88.9 x 3351mm	13.64kg
---	---------	---	-------------------	---------

3	8008561		8x M10x86 HDG	0.04kg
---	---------	---	---------------	--------

4	8042812		4x ISO7042-M16-8	0.043kg
---	---------	---	------------------	---------

5	SW31244		6x Ø90 x 143 mm	0.2kg
---	---------	---	-----------------	-------

6	8027762		8x M6x25-8.8-(ISO7380)	0.006kg
---	---------	---	------------------------	---------

7	8057703		4x ISO4014-M16x120-8.8	0.2280kg
---	---------	---	------------------------	----------

8	8058078		4x ISO7092-17x28x2.5	0.008kg
---	---------	---	----------------------	---------

9	SW5097		1x Ø88.6 x 3870mm	26.11kg
---	--------	---	-------------------	---------

10	SW31278		4x 60 X 60 X 220mm	1.41kg
----	---------	---	--------------------	--------

# SW51357

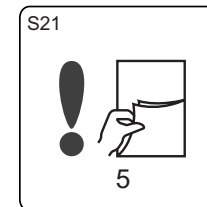
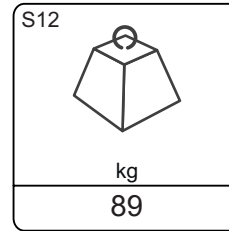
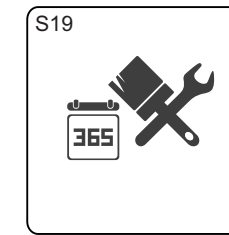
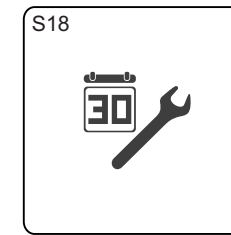
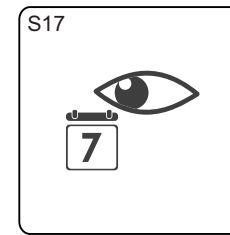
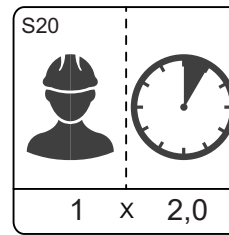

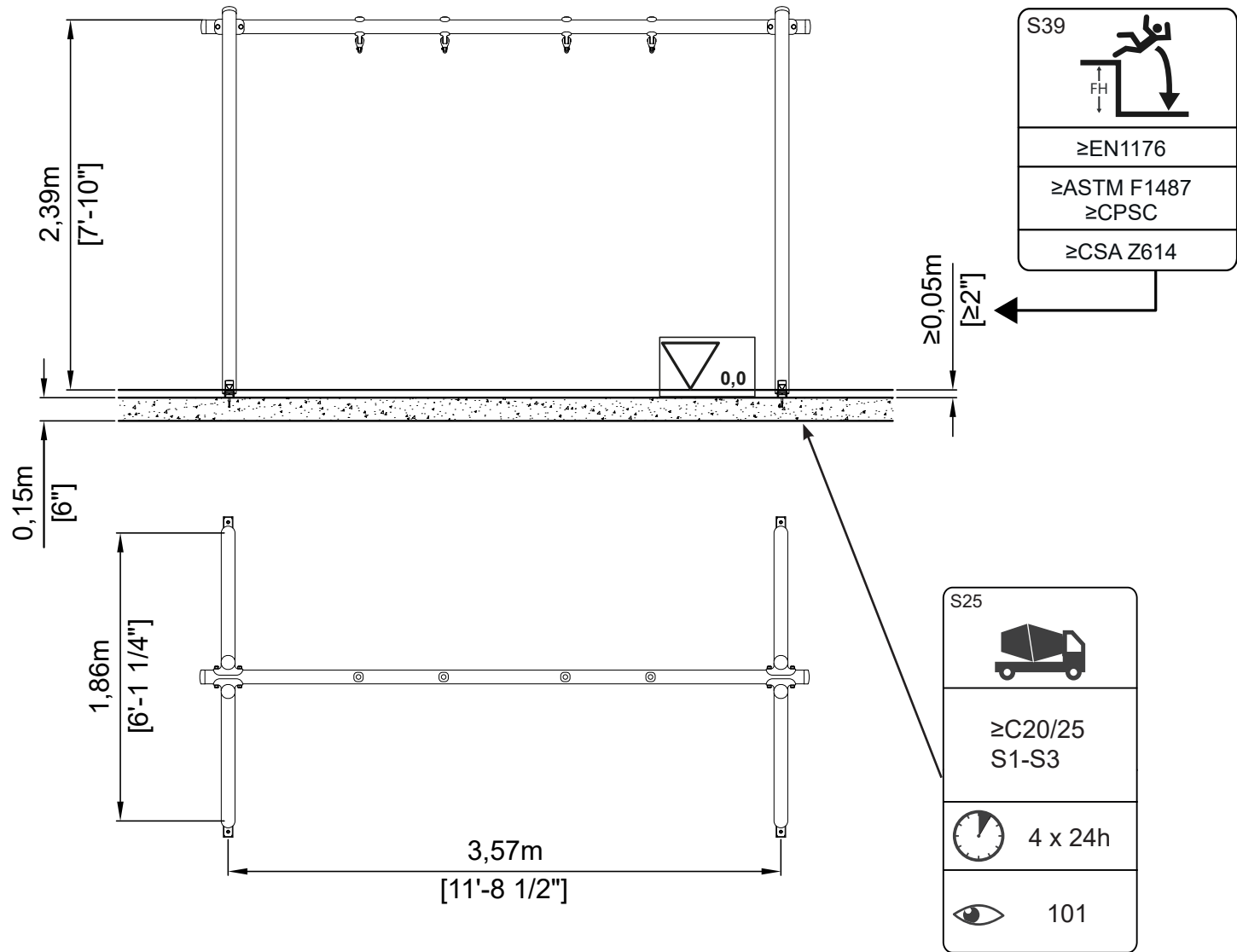

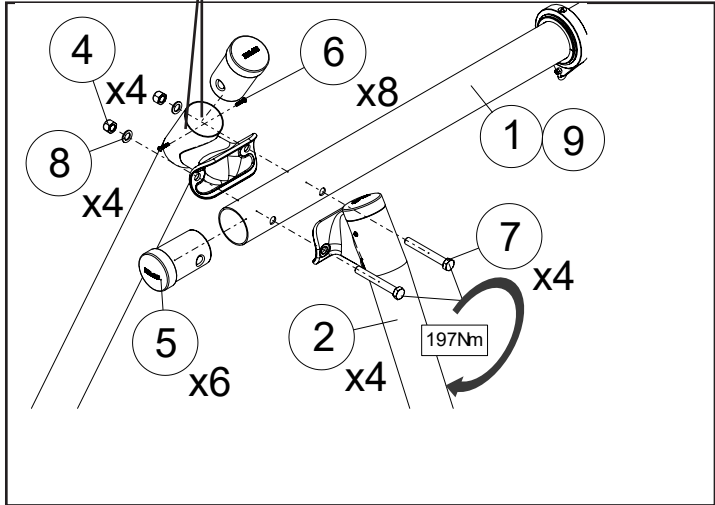
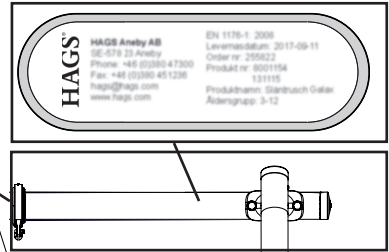
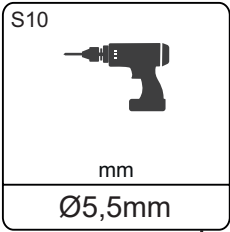

SW73159 & SW51357

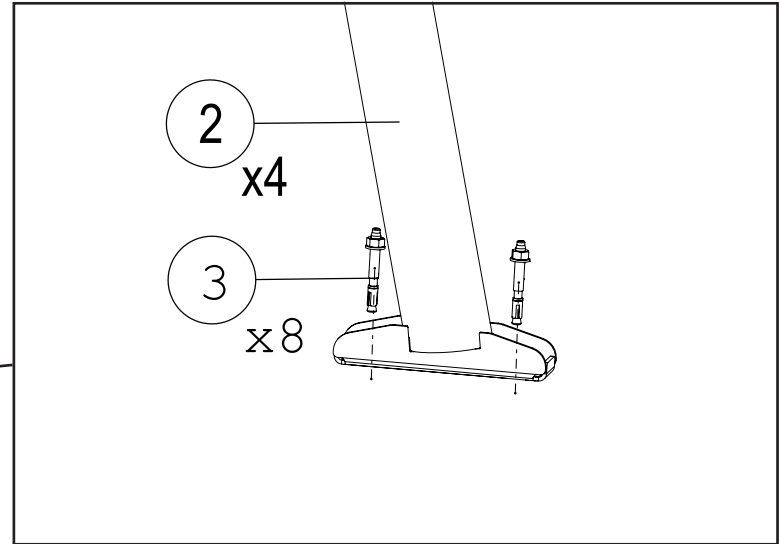
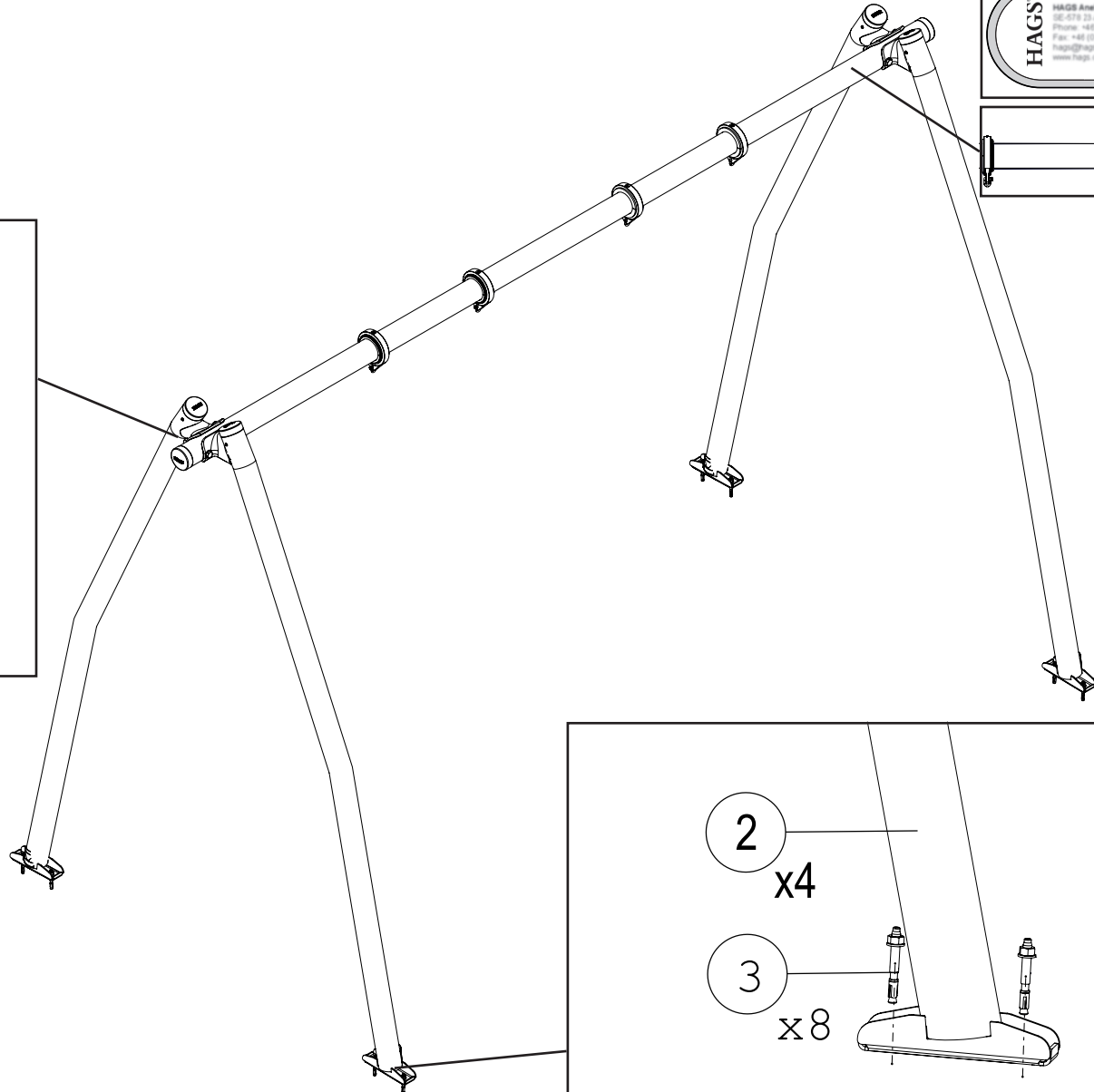

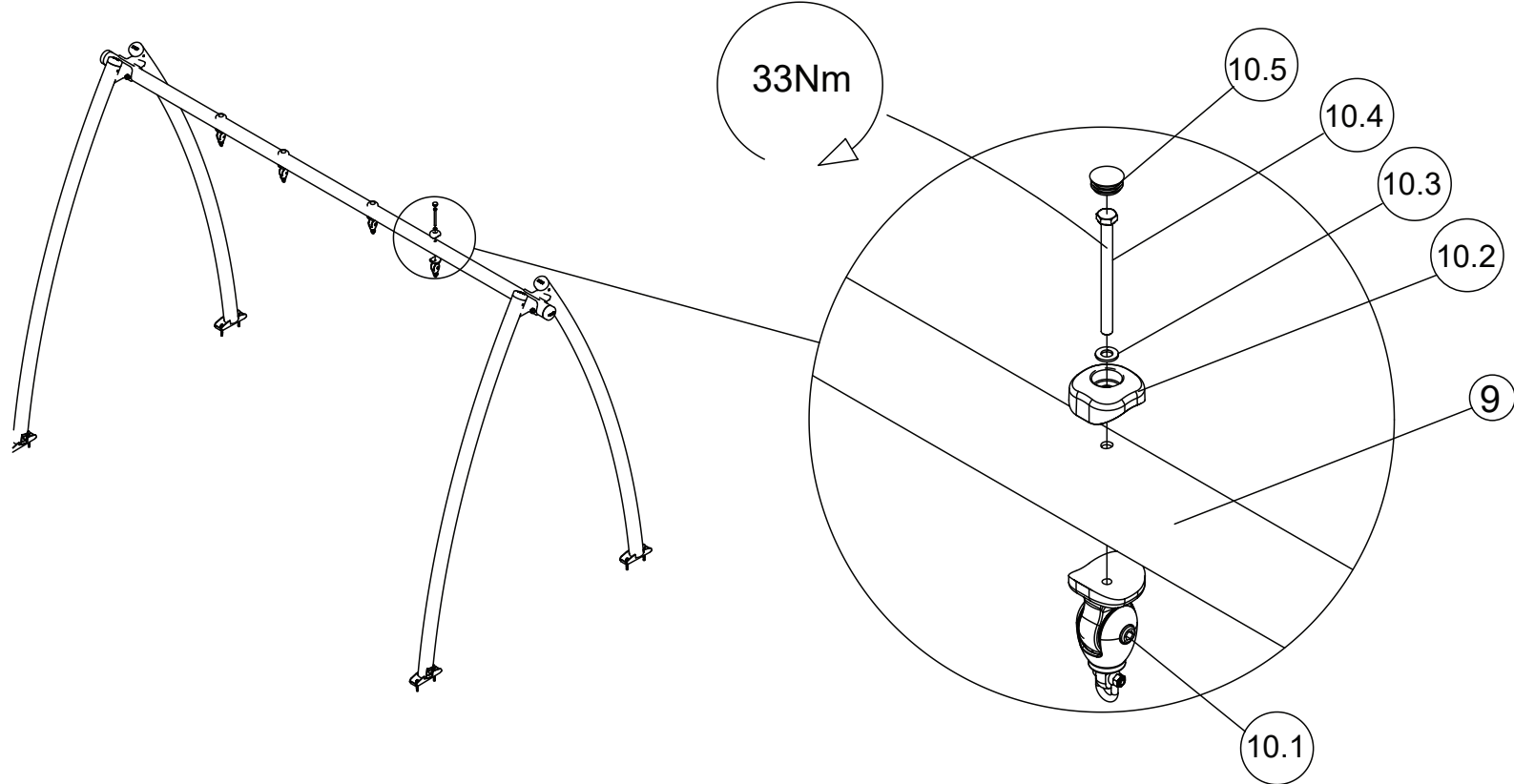

NR.	Description MA	Item Number	Qty
10.1	Swing joint	8050617	4
10.2	Cover		
10.3	Ø11x24x2		
10.4	M6S M10x120 mm		
10.4	Top cover		

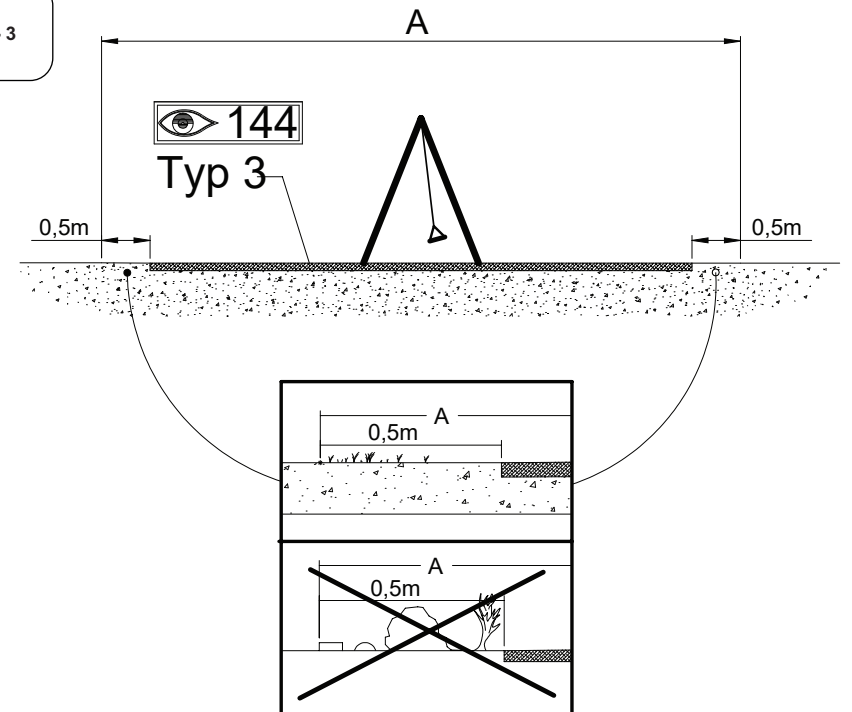
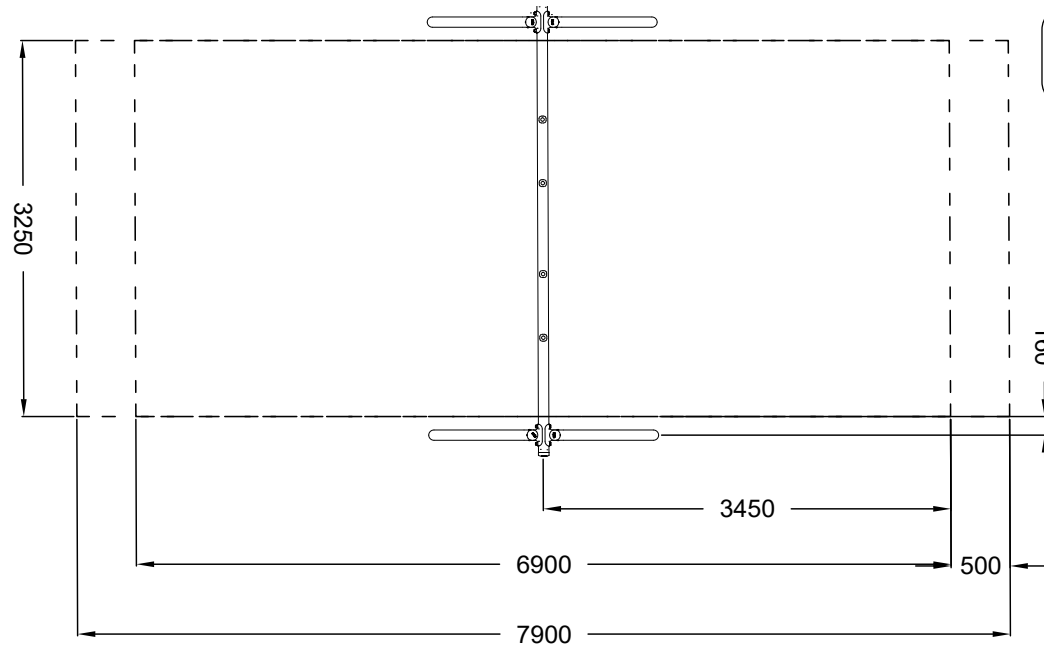
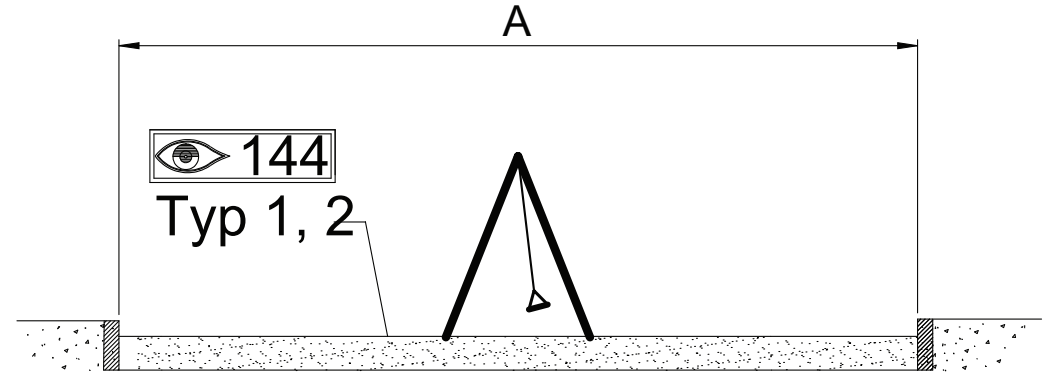
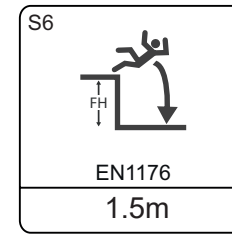
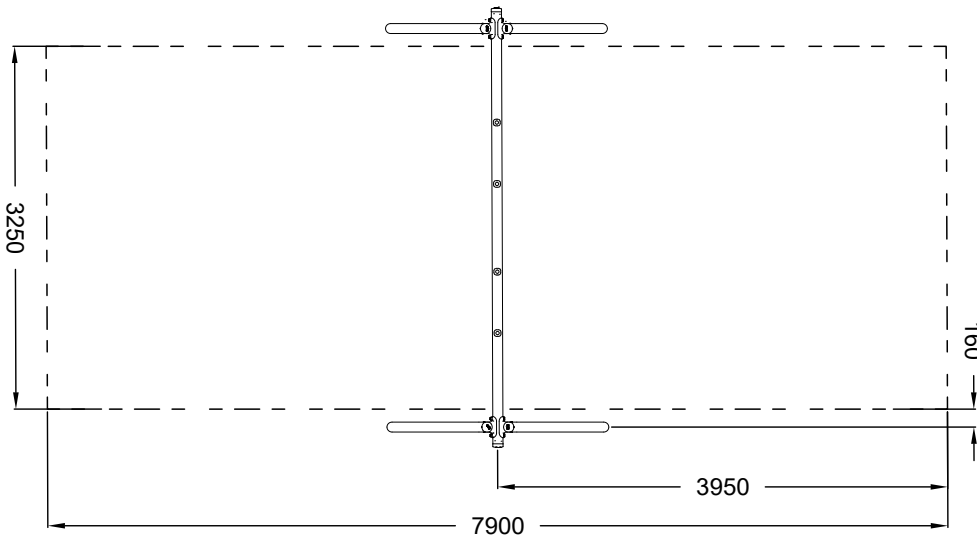

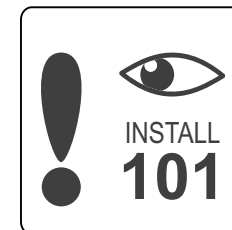
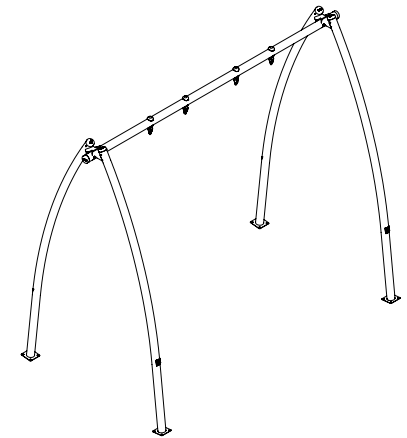
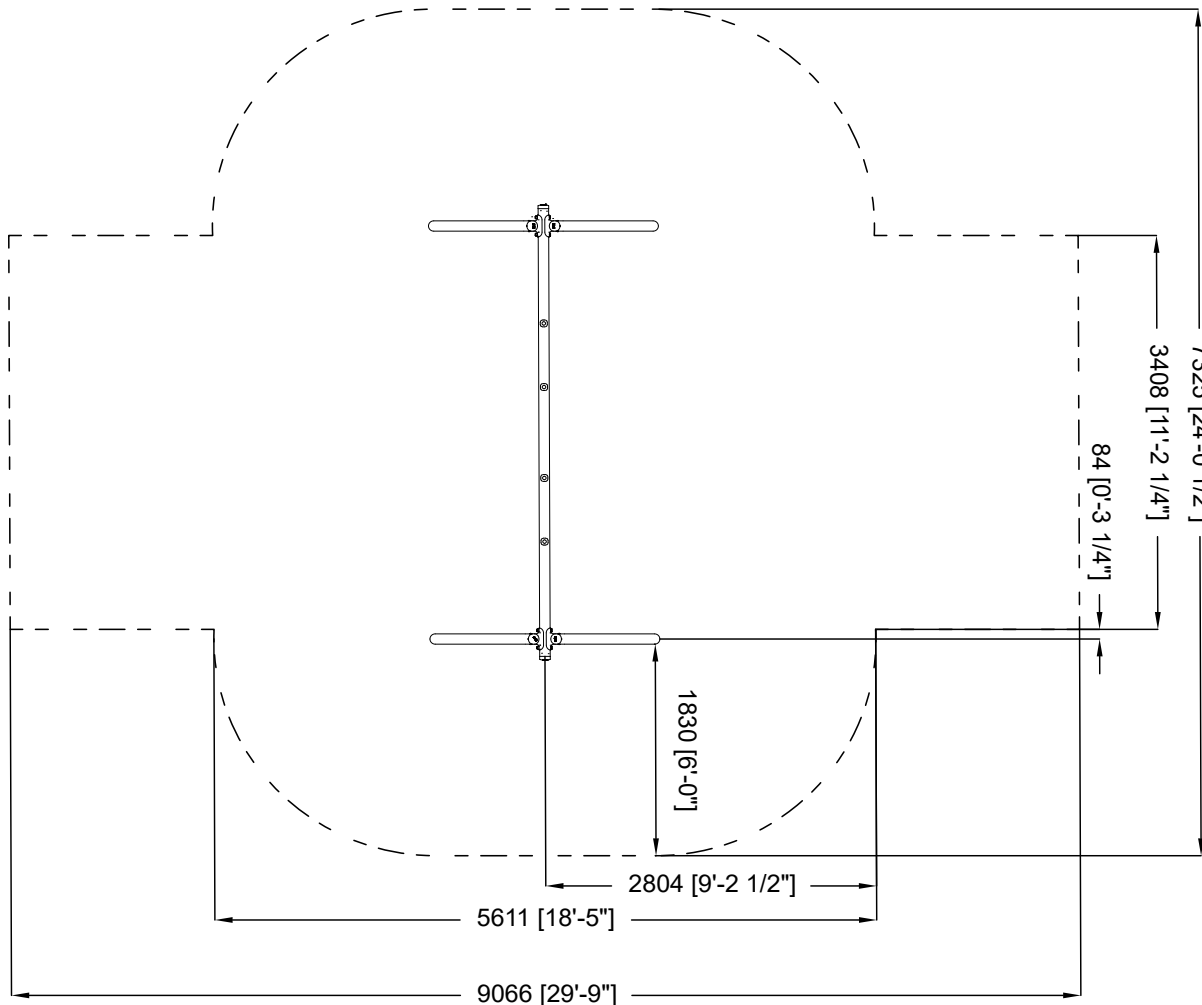
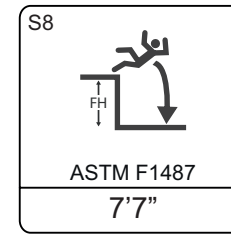
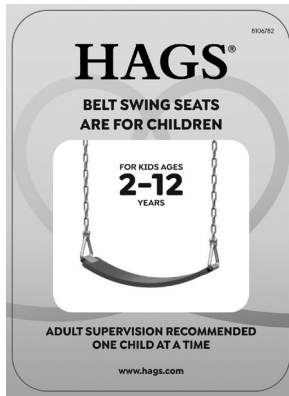

**WARNING**  
Playground equipment installed over hard surfaces such as concrete, asphalt or packed earth may result in serious injury or death from falls. Make sure that appropriate safety surfacing is present, before allowing children to play.

**WARNING**  
Children have strangled and died while their clothes caught on slides and other playground equipment. Before allowing children to play, remove helmets, scarves, necklaces, hood cords, neck drawstrings, and mittens connected through the sleeves. Also, remove any foreign ropes, strings, or shoe laces that may be tied to equipment.

**WARNING**  
All playground equipment and rubber surfacing may become hot enough to cause burns. Check for hot surfaces before allowing children to play. Children should wear appropriate shoes at all times.

**WARNING**  
Playing tag or running on or under playground equipment can lead to serious injuries from falls, collisions, and head strikes. Do not run on or under playground equipment. Pay attention while playing and be careful.

**"play smart" rules**

- ✓ Do not play on broken or damaged equipment. Report it.
- ✓ Do not play without adequate safety surfacing below and around equipment.
- ✓ No helmets, necklaces or drawstrings should be worn while on equipment.
- ✓ Be careful of hot paly surfaces and always wear shoes while playing.
- ✓ Do not play tag or run on playground equipment and do not jump off of equipment.
- ✓ Watch your head! Do not run under bridges, decks, stairs, or other equipment.
- ✓ Be careful when equipment is wet. Do not play on snowy or icy equipment.
- ✓ Do not climb on roofs, railings, or posts, or on top of crawl through tube slides.
- ✓ Slide sitting down, feet first, and one at a time. Do not slide up chutes or tubes.
- ✓ Adults - do not slide with a child on your lap. It can injure your child's legs.
- ✓ Before letting go of overhead bars, hang down still, bend your knees a little and drop straight down with both feet.
- ✓ Swing sitting down and do not jump out while swinging. Do not twist chains.

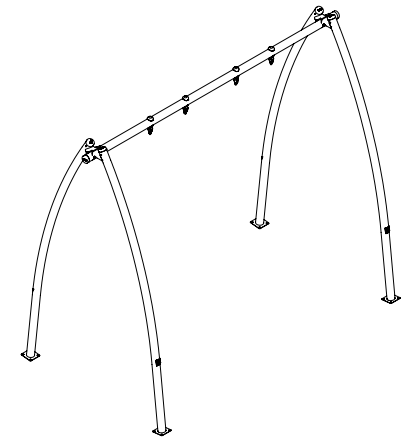
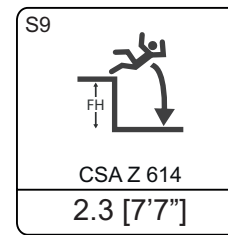
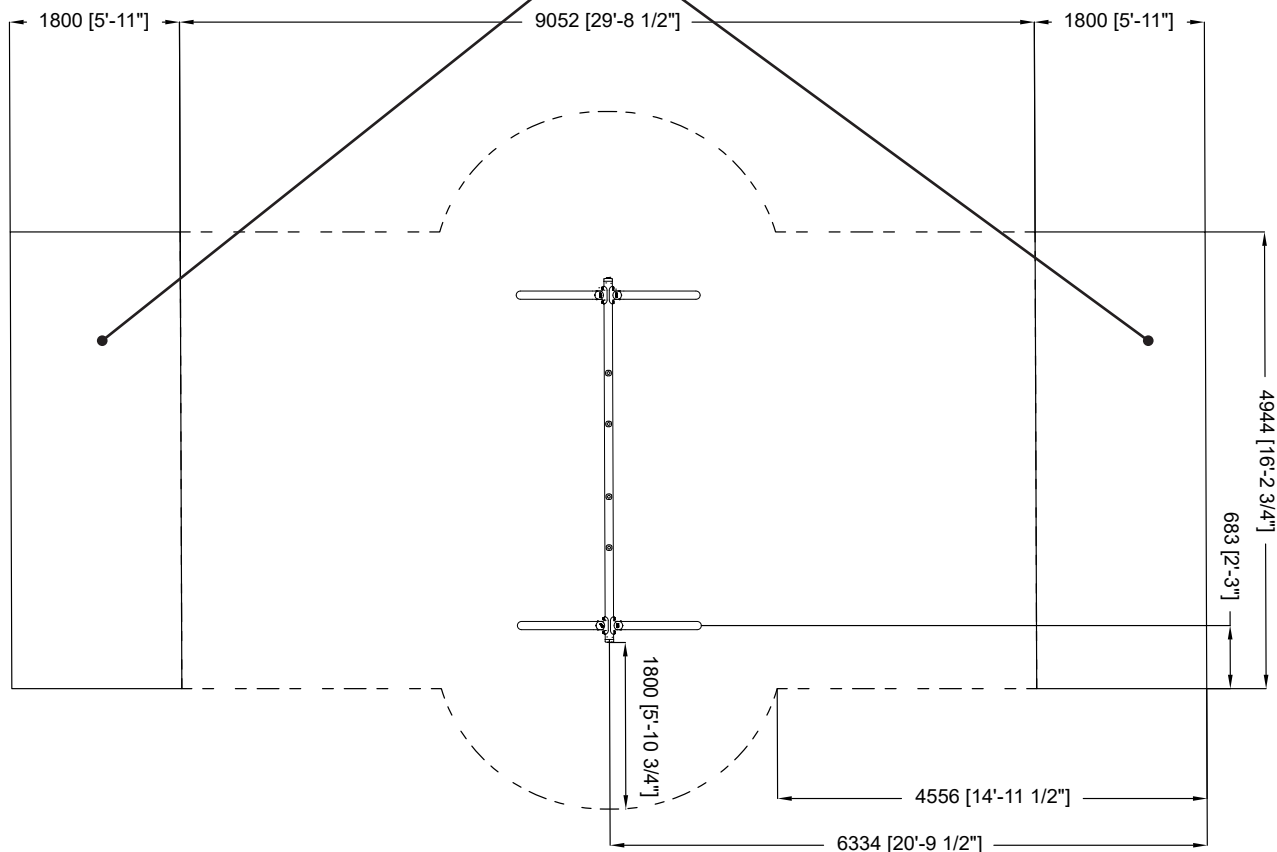
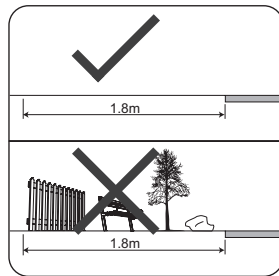

**WARNING**  
Playground equipment installed over hard surfaces such as concrete, asphalt or packed earth may result in serious injury or death from falls. Make sure that appropriate safety surfacing below and around equipment is present, before allowing children to play.

**WARNING**  
Children have strangled and died while their clothes caught on slides and other playground equipment. Before allowing children to play, remove helmets, scarves, necklaces, hood cords, neck drawstrings, and mittens connected through the sleeves. Also, remove any foreign ropes, strings, or shoe laces that may be tied to equipment.

**WARNING**  
All playground equipment and rubber surfacing may become hot enough to cause burns. Check for hot surfaces before allowing children to play. Children should wear appropriate shoes at all times.

**WARNING**  
Playing tag or running on or under playground equipment can lead to serious injuries from falls, collisions, and head strikes. Do not run on or under playground equipment. Pay attention while playing and be careful.

**"play smart" rules**

- ✓ Do not play on broken or damaged equipment. Report it.
- ✓ Do not play without adequate safety surfacing below and around equipment.
- ✓ No helmets, necklaces or drawstrings should be worn while on equipment.
- ✓ Be careful of hot paly surfaces and always wear shoes while playing.
- ✓ Do not play tag or run on playground equipment and do not jump off of equipment.
- ✓ Watch your head! Do not run under bridges, decks, stairs, or other equipment.
- ✓ Be careful when equipment is wet. Do not play on snowy or icy equipment.
- ✓ Do not climb on roofs, railings, or posts, or on top of crawl through tube slides.
- ✓ Slide sitting down, feet first, and one at a time. Do not slide up chutes or tubes.
- ✓ Adults - do not slide with a child on your lap. It can injure your child's legs.
- ✓ Before letting go of overhead bars, hang down still, bend your knees a little and drop straight down with both feet.
- ✓ Swing sitting down and do not jump out while swinging. Do not twist chains.